



Operating Instructions

For

35mm Film Projector

Manual Turret Model P35GPS(Z)-MT

Automatic Turret Model P35GPS(Z)-AT

115VAC, 60Hz Motor or 220VAC, 50Hz Motor

TD-621: Version 3.8

CHRISTIE DIGITAL SYSTEMS

10550 Camden Drive

Cypress, CA 90630

Tel: 714-236-8610 Fax: 714-503-3385

**Operator's Manual
P35GPS-MT/P35GPS-AT
TD621GPS (Z)**

The information in this document is subject to change without notice and does not represent a commitment on the part of CHRISTIE, DIGITAL SYSTEMS (hereinafter referred to as CHRISTIE). CHRISTIE does not assume responsibility for errors that may appear in this document. CHRISTIE or its subsidiaries, designated representatives, and any other vendor of the P35GPS Film Projector are not responsible in any way for any liabilities or loss resulting from the use or misuse of this document.

Copyright © 1998 by CHRISTIE, DIGITAL SYSTEMS
All Rights Reserved

Ultramittent© is a copyright of CHRISTIE, DIGITAL SYSTEMS.
All other copyrights and trademarks are the property of their respective owners.

CHRISTIE
DIGITAL SYSTEMS
10550 Camden Drive
Cypress, CA 90630
Telephone 714-236-8610
FAX 714-503-3385

TABLE OF CONTENTS

TABLE OF CONTENTS.....	i
LIST OF FIGURES AND TABLES.....	v
<hr/>	
1. INTRODUCTION	1-1
<hr/>	
1.1. Contents of the Manual.....	1-1
1.2. Who Should Use This Manual?.....	1-1
1.3. Special Notices	1-1
1.3.1. Warning	1-2
1.3.2. Caution	1-2
1.3.3. Note	1-2
2. General Description.....	2-1
<hr/>	
2.1. Optional Features.....	2-1
2.2. Specifications.....	2-1
3. Projector installation and Assembly.....	3-1
<hr/>	
3.1. Unpacking the Projector	3-1
3.2. Installation	3-1
3.3. Electrical Connections.....	3-3
3.3.1. Solar Cell Wiring.....	3-3
3.3.2. A-C Projector Wiring.....	3-4
4. OPERATING THE PROJECTOR.....	4-1
<hr/>	
4.1. General.....	4-1
4.2. Pre-Operating Procedures.....	4-1
4.2.1. Flywheel Installation	4-1
4.2.2. Turret Installation	4-1
4.2.3. Lens Installation	4-2
4.3. Film Threading and Operating Procedure	4-2
5. MAINTENANCE	5-1
<hr/>	
5.1. General Maintenance.....	5-1
5.2. Visual Inspection	5-1
5.3. Cleaning.....	5-2
5.4. Removal of Assemblies.....	5-2
5.4.1. Removal of the Trap and Gate Assembly.....	5-2

5.4.2. Outer Timing Belt	5-3
5.4.3. Inner Timing Belt.....	5-3
5.4.4. Shutter Timing Belt.....	5-4
5.4.5. Upper, Center, and Lower Constant-Speed Sprocket Assemblies.....	5-5
5.4.6. Ultramittent Assembly	5-6
5.4.7. Removal of LED Soundhead and Solar Cell Assembly.....	5-6
5.4.8. Removal of Digital Soundhead Assembly	5-6
5.4.9. Removal of Electric Changeover Assembly	5-6
5.4.10. Removal of Shutter Driver Assembly	5-7
5.4.11. Removal of Motor Assembly	5-7
5.4.12. Removal of Fan	5-7
5.4.13. Removal of Framing Lamp	5-7

6. CALIBRATION, ALIGNMENT, AND ADJUSTMENT PROCEDURES. 6-1

6.1. LED Soundhead Alignment and Adjustments	6-1
6.1.1. Preliminary Procedures	6-2
6.1.2. Cell Positioning: Vertical Alignment.....	6-2
6.1.3. Horizontal Alignment	6-2
6.1.4. Focus and Azimuth	6-2
6.1.5. Alignment Verification	6-3
6.1.6. Performance Check: Crosstalk.....	6-3
6.1.7. Illumination Uniformity.....	6-3
6.1.8. Final Check	6-3
6.2. Digital Soundhead Alignment.....	6-3
6.2.1. Preliminary Steps	6-3
6.2.2. Alignment Procedure	6-4
6.3. Dashpot Adjustment.....	6-5
6.4. Inner, Outer, and Shutter Timing Belt Adjustment.....	6-5
6.4.1. Inner Timing Belt.....	6-5
6.4.2. Shutter Timing Belt.....	6-5
6.4.3. Outer Timing Belt	6-6
6.5. Shutter Timing.....	6-6
6.6. The CHRISTIE Dual-Lens Turret	6-7
6.6.1. General Description	6-7
6.6.2. The Manual Turret System	6-7
6.6.3. The Automatic Turret System.....	6-7
6.6.4. Timing Adjustments – Turret and Aperture Motor.....	6-8
6.7. Optical Image Alignment and Adjustment Procedures.....	6-8

7. Troubleshooting Procedures 7-1

7.1. Motor.....	7-1
7.1.1. SYMPTOM: Motor Not Working.....	7-1
7.2. Ultramittent Assembly	7-2
7.2.1. SYMPTOM: Excessive Ticking	7-2
7.2.2. SYMPTOM: Excessive Film Noise.....	7-2
7.2.3. SYMPTOM: Film Instability (Jump).....	7-2

7.2.4. SYMPTOM: Shutter Streaking	7-2
7.3. Constant-Speed Sprocket Assembly	7-2
7.3.1. SYMPTOM: Excessive Noise	7-2
7.3.2. SYMPTOM: Film Sprocket Hole Damage	7-2
7.3.3. SYMPTOM: Sprocket Riding	7-2
7.4. Belts	7-3
7.4.1. SYMPTOM: Excessive Noise	7-3
7.4.2. SYMPTOM: Excessive Belt Dust	7-3
7.4.3. SYMPTOM: Excessive Belt Failure	7-3
7.5. Changeover Assembly	7-3
7.5.1. SYMPTOM: Operating Inconsistently	7-3
7.5.2. SYMPTOM: Not Operating	7-3

7.6. Shutter Drive (Shutter Driver and Jackshaft System)	7-3
7.6.1. SYMPTOM: Excessive Noise	7-3
7.6.2. SYMPTOM: Shutter Streak	7-4
7.7. Trap and Gate Assembly	7-4
7.7.1. SYMPTOM: Excessive Jump and Weave	7-4
7.7.2. SYMPTOM: Aperture Binding	7-4
7.8. Lens Turret	7-4
7.8.1. SYMPTOM: Not Rotating	7-4
7.8.2. SYMPTOM: Focus Knob Inoperative	7-4
7.8.3. SYMPTOM: Turret Hinge Too Loose	7-5
7.8.4. SYMPTOM: Turret Hinge Too Tight	7-5

Appendix A: Replaceable Assemblies and Components A-1

Appendix B: Diagrams and Parts Lists P35GPS..... B-1

B-1: Changeover Douser Assembly	B-2
B-2: Automatic Curved Trap and Gate Assembly	B-4
B-3: Fixed Idler Assembly	B-8
B-4: Fixed Idler Assembly, Flanged	B-9
B-5: Jackshaft Assembly	B-10
B-6: Center and Upper Constant-Speed Sprocket Assembly	B-11
B-7: Lower Constant-Speed Sprocket Assembly	B-Error! Bookmark not defined.
B-8: Shutter Driver Assembly	B-15
B-9: 30-Groove Flanged Idler Assembly	B-17
B-10: Outer Timing Belt Tensioner Assembly	B-18
B-11: Inner Timing Belt Tensioner Assembly	B-19
B-12: Central Pivot Analog Soundhead Assembly	B-20
B-13: Central Pivot Digital Soundhead Assembly	B-22
B-14: Intermittent Shoe Closure	B-25

Appendix C: Schematic Diagrams C-1

Index C-5

LIST OF FIGURES AND TABLES

Figure 2-1: Table of Equipment Specifications	2-1
Figure 2-2: Projector, Front View	2-2
Figure 2-3: Projector, Rear View	2-3
Figure 3-1: Installing the Projector	3-2
Figure 3-2: Tools and Materials Required for Assembly and Maintenance	3-3
Figure 3-3: Projector Wiring Diagram (50- and 60-Hz models)	3-4
Figure 3-4: Table of A-C Terminal Connections	3-5
Figure 4-1: Threading Diagram	4-3
Figure 5-1: Schedule for Periodic Maintenance Operations	5-1
Figure 5-2: Outer Timing Belt	5-3
Figure 5-3: Inner Timing Belt	5-4
Figure 5-4: Shutter Timing Belt	5-5
Figure 6-1: Analog Reader Alignment and Adjustments	6-1
Figure 6-2: Digital Reader Assembly	6-4
Figure 6-3: Dual Turret (Front View)	6-7
Figure 6-4: Dual Turret (Rear View)	6-8
Table A-1: P35GPS Projector Replaceable Assemblies and Components	A-1
Figure B-1: Changeover Douser Assembly (P/N 196601-001)	B-2
Table B-1: Changeover Douser Assembly Parts List	B-3
Figure B-2: Automatic Curved Trap and Gate Assembly (P/N 196556-001)	B-4
Table B-2: Parts List for Automatic Curved Trap and Gate Assembly	B-7
Figure B-3: Fixed Idler Assembly (P/N 194756-001)	B-8
Table B-3: Fixed Idler Assembly Parts List	B-8
Figure B-4: Fixed Idler Assembly, Flanged (P/N 194756-002)	B-9
Table B-4: Fixed Idler Roller Assembly, Flanged, Parts List	B-9
Figure B-5: Jackshaft Assembly (P/N 194810-001)	B-10
Table B-5: Jackshaft Assembly Parts List	B-10
Figure B-6: Center and Upper Constant-Speed Sprocket Assembly (P/N 194856-001)	B-11
Table B-6: Center and Upper Constant-Speed Sprocket Assembly Parts List	B-12
Figure B-7: Lower Constant-Speed Sprocket Assembly (P/N 194857-001)	B-13
Table B-7: Lower Constant-Speed Sprocket Assembly Parts List	B-14
Figure B-8: Shutter Driver Assembly (P/N 194866-001)	B-15
Table B-8: Shutter Driver Assembly Parts List	B-16
Figure B-9: 30-Groove Flanged Idler Assembly (P/N 194880-001)	B-17
Table B-9: 30-Groove Flanged Idler Assembly Parts List	B-17
Figure B-10: Outer Timing Belt Tensioner Assembly (P/N 196055-001)	B-18
Table B-10: Outer Timing Belt Tensioner Assembly Parts List	B-18
Figure B-11: Inner Timing Belt Tensioner Assembly (P/N 196056-001)	B-19

Table B-11 Inner Timing Belt Tensioner Assembly Parts List B-19
Figure B-12: Central Pivot Analog Soundhead Assembly (P/N 196260-001)..... B-20
Table B-12 Central Pivot Analog Soundhead Assembly Parts List B-21
Figure B-13: Central Pivot Digital Soundhead Assembly (P/N 196220-002) B-22
Table B-13: Central Pivot Digital Soundhead Assembly Parts List..... B-24
Figure B-14: Intermittent Shoe Closure Assembly (P/N 120651M001)..... B-25
Table B-14: Intermittent Shoe Closure Assembly Parts List B-26
Table C- 1: Schematic Diagrams for P35GPS Projector C-1

1. INTRODUCTION

1.1. CONTENTS OF THE MANUAL

This manual contains installation, operation, and operator maintenance procedures for CHRISTIE P35GPS Projector models having serial numbers P-1201 and up. The material covered includes:

- general description
- installation and assembly
- operating the projector
- periodic maintenance
- calibration, alignment, and adjustments
- troubleshooting.

1.2. WHO SHOULD USE THIS MANUAL?

This manual provides information suitable for various purposes. For details on operating the projector and for general information, see:

- *Section 2: General Description*
- *Section 3: Installation and Assembly*
- *Section 4: Operating the Projector.*

Before performing adjustments and periodic maintenance during normal operation, see:

- *Section 5: Periodic Maintenance*
- *Section 6: Calibration, Alignment, and Adjustments.*

If a problem occurs, see:

- *Section 7: Troubleshooting Procedures.*

Additional reference information is contained in the appendices.

1.3. SPECIAL NOTICES

Three kinds of specific notices are used within this manual to emphasize specific information.

1.3.1. WARNING



WARNING: Indicates the presence of a hazard that can cause personal injury if the hazard is not avoided.

WARNING

1.3.2. CAUTION



CAUTION: Indicates the presence of a hazard that could cause damage to projection system.

1.3.3. NOTE

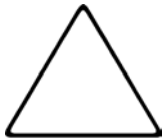

NOTE: Provides additional information.

2. GENERAL DESCRIPTION

The CHRISTIE P35GPS Projector, manufactured exclusively by CHRISTIE DIGITAL SYSTEMS in Cypress, California, is a dual-lens 35mm movie projector that employs a revolutionary sealed-bearing intermittent movement called the Ultramittent©. This movement coupled with uncompromising design and assembly workmanship, results in the finest possible theater picture reproduction. The Ultramittent movement is standard on all CHRISTIE projectors.

2.1. OPTIONAL FEATURES

Options available for enhancing the standard features of the P35GPS projector include:

- manual dual-lens turret
- automatic dual or triple lens turret, including automatic aperture changer
- inboard Dolby digital reader
- all models available in 50 Hz or 60 Hz

2.2. SPECIFICATIONS

Standard specifications for the P35GPS projector family are listed in the Table shown in Figure 2-1, below.

<u>POWER REQUIREMENTS:</u>	
Input Voltage	115 VAC, 5 Amp, 60 Hz OR 220 VAC, 3 Amp, 50 Hz
<u>DIMENSIONS:</u>	
Height	23 inches
Width	18 inches
Depth	16 inches
<u>WEIGHT:</u>	Standard: approximately 90 lb.
<u>FILM SPEED:</u>	Standard: 24 frames/sec (90 ft/min)
<u>OPERATING TEMPERATURE:</u>	0 to +45°C
<u>MOTOR:</u>	Synchronous split phase, 1800 rpm, 60 Hz OR 1500 rpm, 50 Hz

Figure 2-1: Table of Equipment Specifications

These specifications may vary slightly, depending upon the particular model and options chosen.

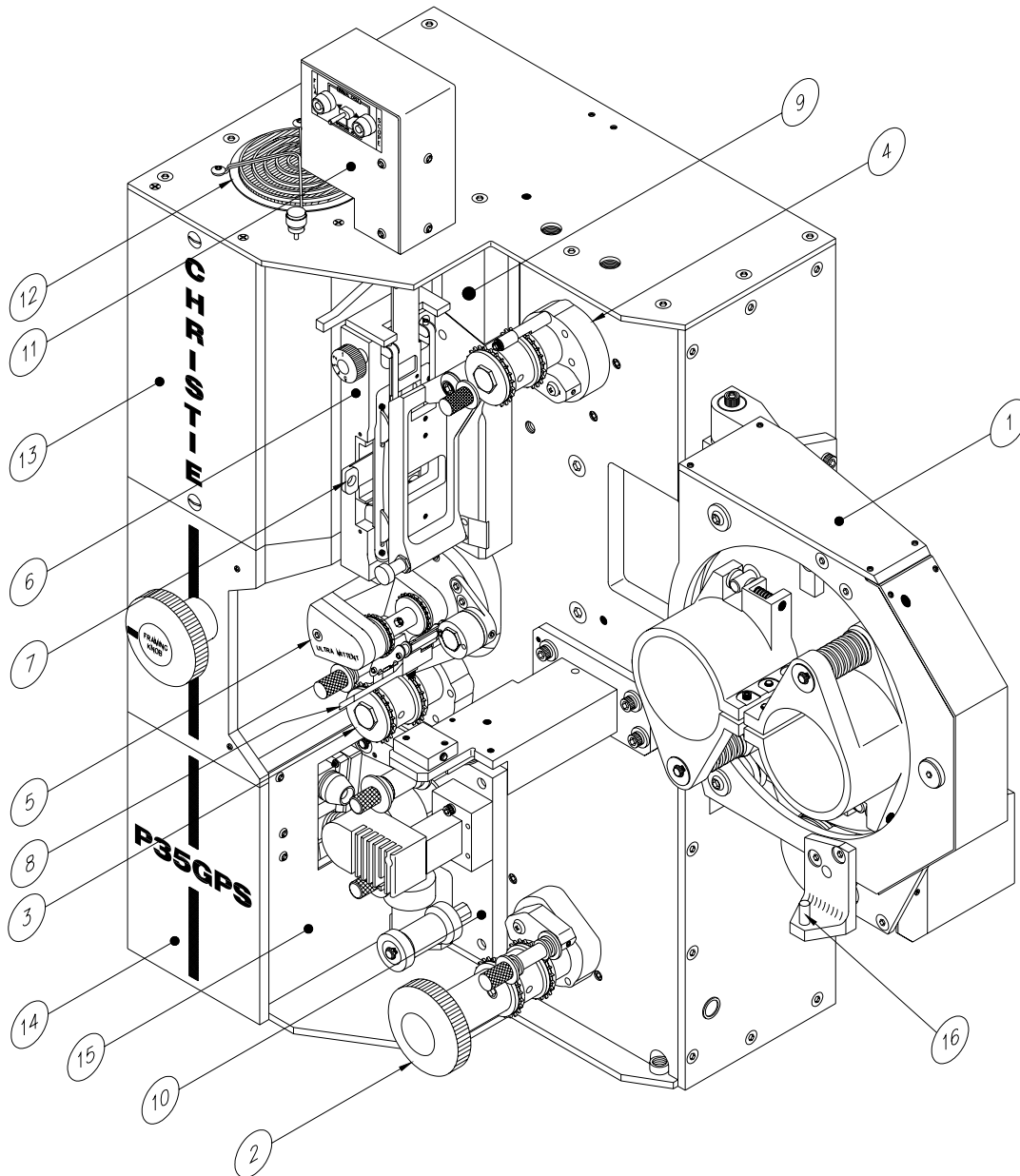

- | | |
|---|---|
| <ul style="list-style-type: none"> 1. *Dual Turret (196555-001) 2. Turndown Knob (194510-001) 3. center sprocket Assembly (194856-002) 4. Upper Sprocket Assembly (194856-0010) 5. Ultramittent Assembly (119450-001) 6. Trap and gate Assembly (196556-001) 7. Aperture plate (121117-00x) 8. Intermittent Shoe closure (120651M001) 9. Shutter belt Cover (598931-533) | <ul style="list-style-type: none"> 10. **Sound-head Assembly-(Analog-
(96260-001,Digital-196220-002) 11. Aperture Drive Assembly (121435-001) 12. Fan Grill (598931-547) 13. Baffle Light Cover (119039-001) 14. Sound-head Access Door (119041-001) 15. **Light Shield (194434-00X) 16. Block Pin Latch(197026-001) |
|---|---|

***Manual or Motorized**

****Analog or Digital**

Figure 2-2: Projector, Operator Side

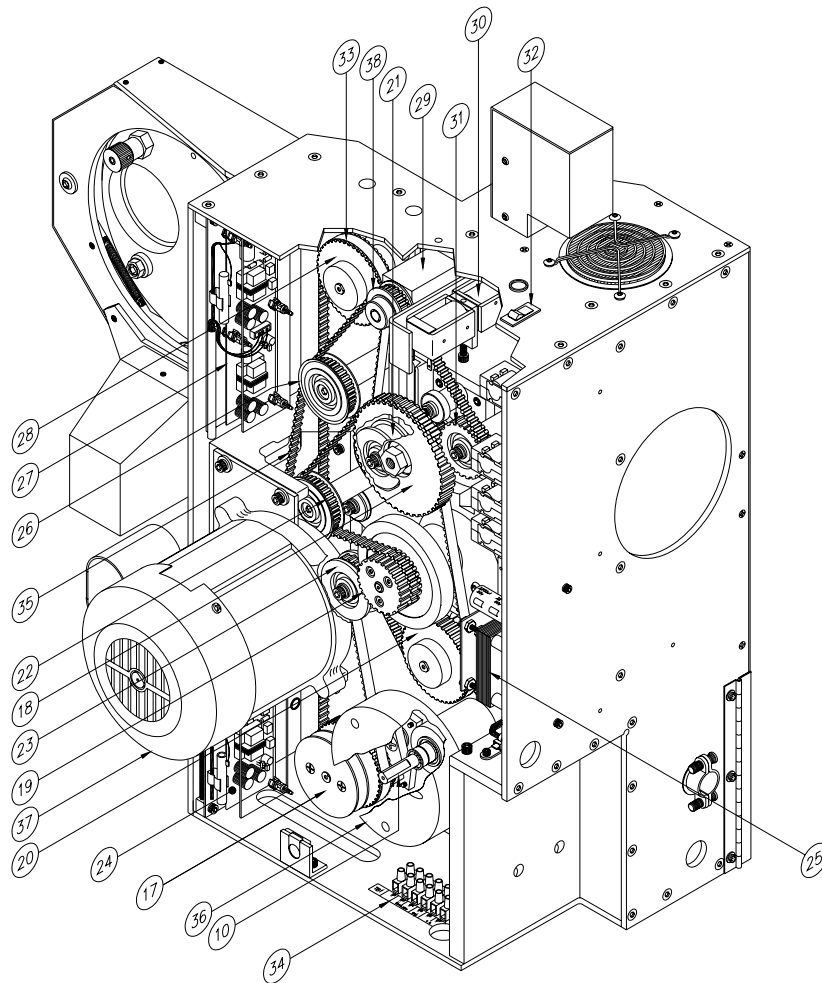

- | | |
|--|--|
| 17. Lower Sprocket Assembly (194857-001) | 27. Analog Power Supply (194908-001) |
| 18. Shutter Driver Assembly (194866-001) | 28. Upper Sprocket Pulley (194858-001) |
| 19. Ultramittent Pulley (194818-001) | 29. Jackshaft Assembly (194810-001) |
| 20. Center Sprocket Pulley (194858-001) | 30. Changeover Dowser (121195-001) |
| 21. Inner Belt Tensioner (196056-001) | 31. Outer Belt Tensioner (196055-001) |
| 22. Flanged Idler Assembly (194880-001) | 32. Framing Light Switch (598931-214) |
| 23. Not used | 33. Inner Timing Belt (598931-179) |
| 10. Sound-drum Shaft (196315-001) | 34. TB1 Connector (586210-602) |
| 24. Digital LED Supply (194834-001) | 35. Outer Timing Belt (598931-528) |
| 25. Turret Control Module (121428-001) | 36. Sound-drum Flywheel (119166-001) |
| 26. Flanged Idler Assembly (194880-001) | 37. Motor Assembly (50- or 60-Hz) |
| | 38. Pulley 20 Grooves (194820-001) |

Projector 2-3: Projector, Non-Operator

3. PROJECTOR INSTALLATION AND ASSEMBLY

3.1. UNPACKING THE PROJECTOR



Before opening box (es), carefully inspect outside of carton(s). If carton has been damaged, notify shipper immediately; do not open carton unless instructed to do so.

The CHRISTIE P35GPS projector may be shipped in more than one container. Each P35GPS projector normally comes complete with the following items:

- dual aperture plate (shipped in place)
- framing lamp (installed)
- sound-head flywheel (not installed)
- sound-head assembly (factory-aligned)
- dual-lens turret
- drive motor assembly
- instruction manual.

The console and projector are shipped in a single carton, with special pockets containing smaller items. The lens turret and sound-head flywheel are shipped separately.

To unpack:

1. Open carton(s).
2. Remove all protective material from framing lamp, sound-head assembly, and lens holder.
3. Remove protective material around side panel.

3.2. INSTALLATION

To install the projector, refer to Figure 3-1. The required materials and tools for installing and assembling the P35GPS projector are outlined in the Table in Figure 3-2.

1. Loosen but *do not remove* nut on projector mounting stud (item 4 in Figure 3-1). Verify that lock washer (item 5 in Figure 3-1) and flat washer (item 6 in Figure 3-1) are correctly positioned on mounting stud. Flat washer should be next to lock washer, followed by nut.

2. Insert lock washer (item 2 in Figure 3-1) and flat washer (item 3 in Figure 3-1) onto second hex bolt (item 1 in Figure 3-1). Insert hex head bolt, with lock washer and flat washer, into upper left opening of projector mount. Rotate hex head bolt four full turns.
3. Lift and mount projector to console or pedestal. Thread two remaining hex head bolts with lock washer and flat washer. Insert into two bottom mounting holes on projector.
4. Level projector on lamp-house or pedestal.
5. Tighten nut on mounting stud using 9/16" wrench.
6. Tighten three hex head screws using same wrench.

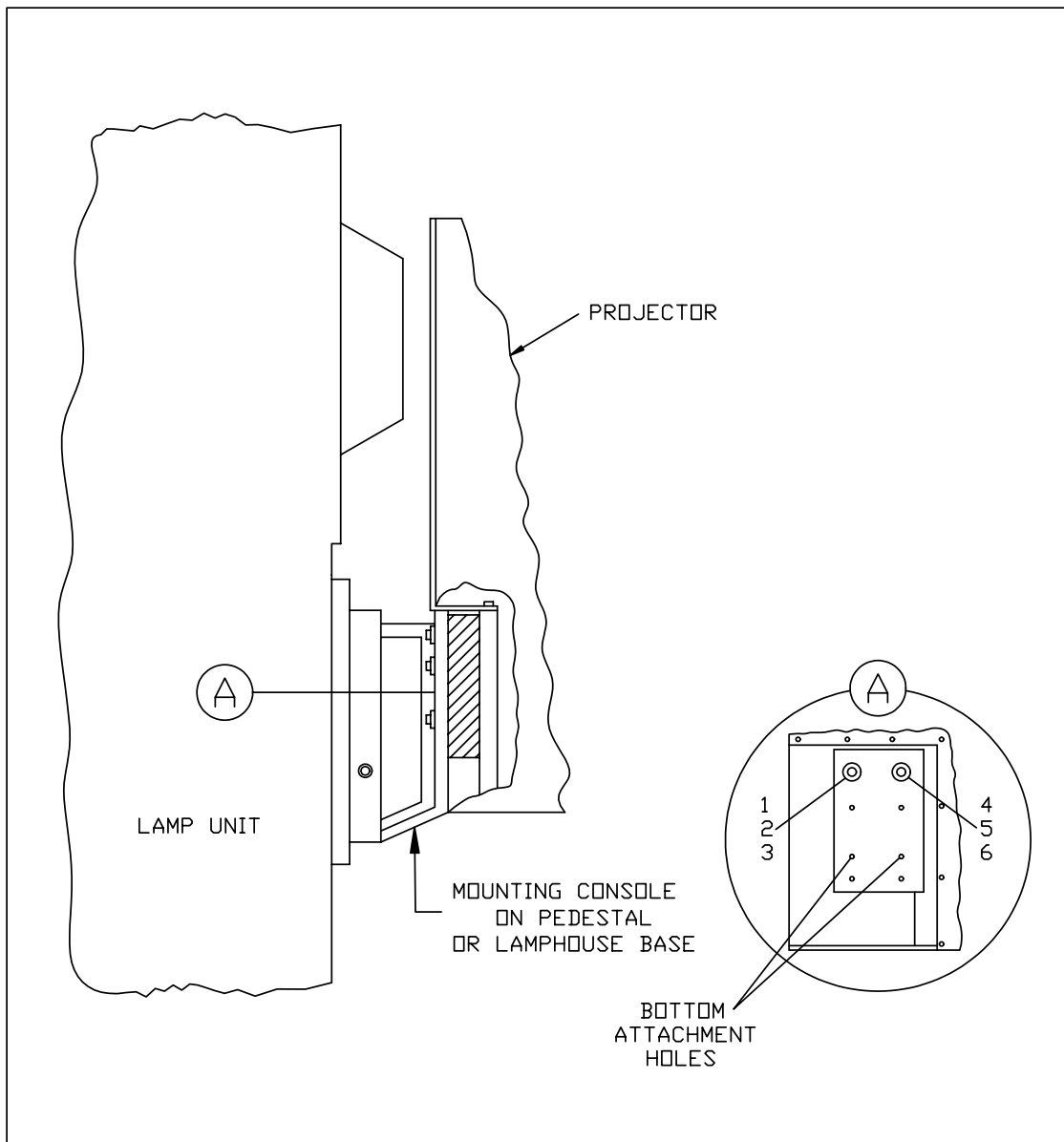

Figure 3-1: Installing the Projector

Category	Item	Use
Tools	Miscellaneous Allen wrenches	General Maintenance
	Small standard screwdriver	
	Phillips screwdrivers	
Equipment	Oscilloscope	Sound-head Alignment
	Voltmeter	
	Real-time Analyzer	
	SK1994-3 alignment tool	Lateral Guide Alignment
Materials	P35-BT (SMPTE)	Buzz Track Test Loop
	P35-FL	Flutter Loop
	Cat 69 Loop	Dolby Tone, Pink Noise
	Cat 566 Loop	Illumination Uniformity
	Cat 97 Loop	Left/Right Alignment
	RP-40 Loop	Optical Alignment

Figure 3-2: Tools and Materials Required for Assembly and Maintenance

3.3. ELECTRICAL CONNECTIONS

Before wiring the projector, refer to Figure 3-3 for the wiring interface diagram. Use stranded wire. Strip and tin the wire prior to connection. Use crimp connectors on all sound connections. For projectors equipped with an automatic turret, refer to Section 6.6.3.

3.3.1. SOLAR CELL WIRING

Solar cell wiring requires a shielded, four-conductor audio cable. (red – left (+), black – left (-), green – right (+), white – right (-)). The best signal-to-noise ratio is achieved by maintaining the same ground potential between the sound-head and the cinema processor. Refer to the directions in the sound system instruction manual for proper connection of the sound system.

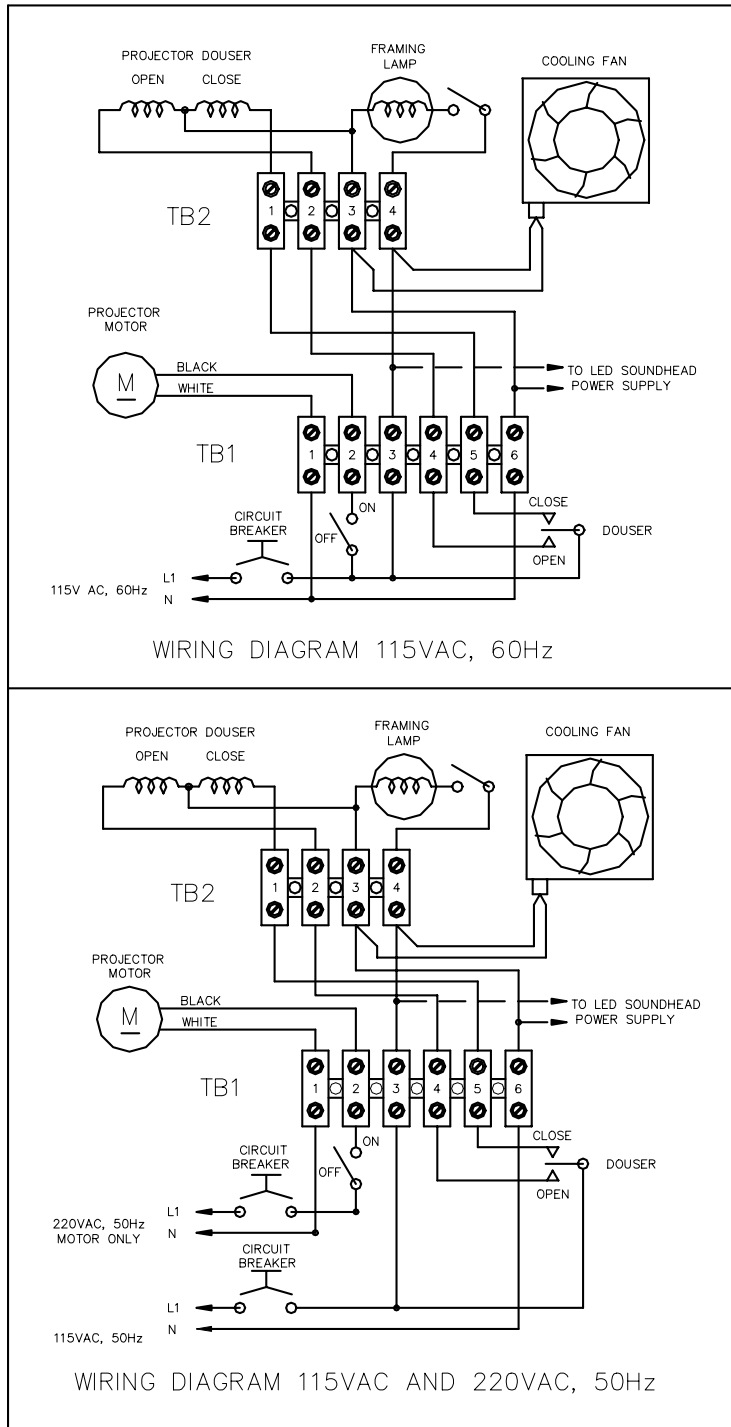

Figure 3-3: Projector Wiring Diagram (50- and 60-Hz models)

3.3.2. A-C PROJECTOR WIRING

A-C wiring to the projector requires stranded, 14-gauge wire. Be sure to follow local and national electrical codes for A-C wiring. The terminal connection numbers in the table in Figure 3-4 refer to terminals TB-1 in Figure 3-3.

Terminal TB1	Connection
1	Motor (A-C neutral)
2	Motor switch lead (A-C hot, switched externally)
3	Framing lamp and cooling fan (A-C hot)
4	Changeover coil OPEN (A-C, switched externally)
5	Changeover coil CLOSE (A-C, switched externally)
6	Framing lamp, cooling fan, and changeover (A-C neutral).

Figure 3-4: Table of A-C Terminal Connections



The voltage and frequency rating of the projector (shown on the nameplate) *must* match the power line frequency and voltage being used.

4

4. OPERATING THE PROJECTOR

4.1. GENERAL

Before operating the projector, verify that all phases of installation and assembly have been completed.



WARNING

- **Verify that cover for belt side of projector is installed before and during operation.**
- **Do not make adjustments on belt side of projector while cover is removed or power is on.**
- **Do not make adjustments or perform maintenance on projector while it is in operation.**

4.2. PRE-OPERATING PROCEDURES

4.2.1. FLYWHEEL INSTALLATION

1. Back out flywheel set screw far enough to let flywheel slide onto shaft without scoring shaft or damaging threads on set screw.
2. Slide flywheel onto shaft until it stops.
3. Position set screw over flat portion of shaft and tighten set screw.
4. Spin flywheel by hand to check for smooth operation.



CHRISTIE recommends that any projector accessories be installed at this time.

4.2.2. TURRET INSTALLATION

1. Secure turret hinge plate with four Allen head screws.
2. Install turret latch assembly using same holes and hardware (if it is not already installed).
3. Connect turret wiring to TB4-1 (Red) and TB4-2 (Black).

4.2.3. LENS INSTALLATION

3. Install lens system in lens holder. If it is necessary to open lens holder wider than normal:
 - a) Loosen two lens-locking screws.
 - b) Turn jack screw clockwise until lens slides into lens holder.
3. Set focus knob at mid-position.
3. Secure lens system with two locking screws.



Over-tightening can cause focus mechanism to bind.

4.3. FILM THREADING AND OPERATING PROCEDURE

Refer to Figure 4-1 for film threading and positioning.

1. Set Ultramittent to its rest position. There should be no sprocket movement when manual turndown knob (N) is turned.
2. Center framing knob (P) by aligning mark on knob with line on projector housing marked CENTER FRAME.
3. Swing out pad rollers (B, F, and L) on upper constant-speed sprocket assembly (A), center constant-speed sprocket assembly (G), and lower constant-speed sprocket assembly (M).
4. Swing out film shoe on Ultramittent assembly (E).
5. Pull out catch knob (D) and swing out trap and gate assembly (C).
6. Using slightly more film length than is required to reach film transport system, begin to thread film into projector.
7. Align film on Ultramittent sprocket and close Ultramittent film shoe.
8. To form proper loop between Ultramittent and center constant-speed sprocket assembly:
 - a) Pull film loosely over pad roller while pad roller is in open position (R) and then onto center constant-speed sprocket.
 - b) Mate film sprocket holes with sprocket roller pins.
 - c) Hold film in position and close pad roller.The required film loop has now been formed.
9. Thread film on sound-head assembly as shown in Figure 4-1:
 - a) Holding two lateral guide rollers (H and K) towards each other, pull film tight and align film on lower constant-speed sprocket assembly (M).
 - b) Tighten film on one sprocket hole so lateral guides barely float off sound drum.

- c) Wrap film around sprocket and close pad roller (L) of lower constant-speed sprocket assembly.

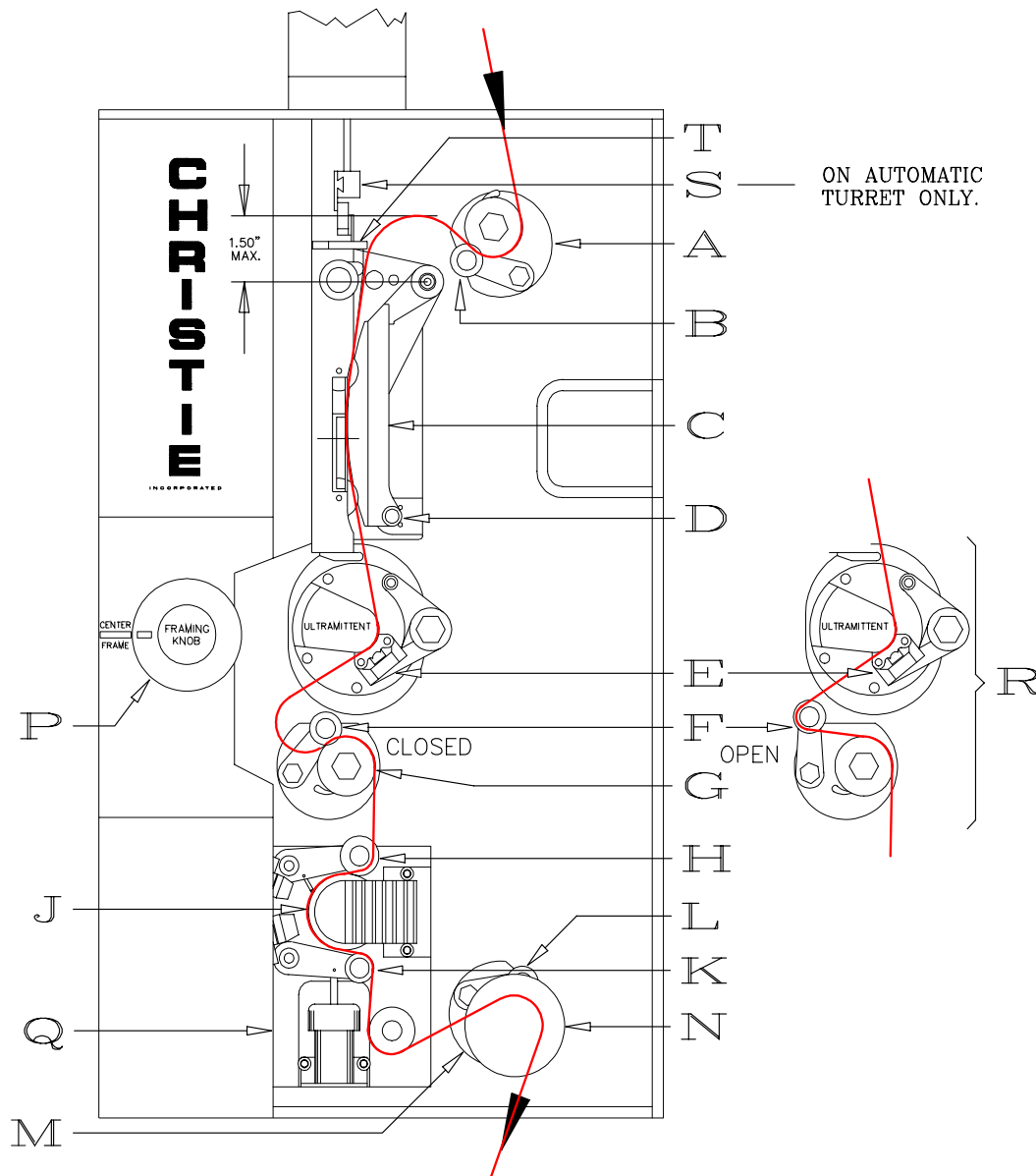

A: Upper constant-speed sprocket assembly	K: Lateral guide roller
B: Upper constant-speed sprocket pad roller	L: Lower constant-speed sprocket pad roller
C: Trap and gate assembly	M: Lower constant-speed sprocket assembly
D: Catch knob	N: Manual turn-down knob
E: Ultramittent assembly	P: Framing knob
F: Center constant-speed sprocket pad roller	Q: Airpot
G: Center constant-speed sprocket assembly	R: Open center constant-speed sprocket pad roller
H: Lateral guide roller	S: Aperture linkage
J: Sound-head Assembly	T: Gate bands

Figure 4-1: Threading Diagram

10. Place film at upper part of Ultramittent in film guide (R).
11. Align film on steel bands of trap and gate assembly (T).
12. Close gate (C) and lock catch knob (D) in place.
13. Form 1.5-inch loop between upper constant-speed sprocket and gate (C), as shown in Figure 4-1.
14. Align the film on upper constant-speed sprocket (A) and close film shoe (B).
15. To verify that film is correctly aligned on all sprocket rollers, move turndown knob (N) clockwise.



- **Framing lamp can be turned “on” or “off” with black rocker switch located on top of projector.**
- **Framing lamp is functional with picture changeover in either position.**
- **If film reel is used, be sure take-up tension is in accordance with reel manufacturer’s instructions.**

5. MAINTENANCE

This projector has been designed to provide years of optimum performance while requiring only routine maintenance and cleaning. However, CHRISTIE strongly recommends a periodic maintenance program of scheduled operational checks and preventive maintenance.

5.1. GENERAL MAINTENANCE

Use the program outlined in the schedule in Figure 5-1 to maximize projector life and operating efficiency. Procedures for these operations are described in the referenced sections of this manual.

Frequency	Maintenance Operation	Section
Daily	Visual inspection	5.2
Daily	Clean projector	5.3
Bi-weekly	Oil lateral guides and jewels	5.3
Annually	Replace belts and blow out belt dust	5.4.2

Figure 5-1: Schedule for Periodic Maintenance Operations

5.2. VISUAL INSPECTION

1. Visually inspect projector for signs of excessive dust, dirt, physical damage, frayed or damaged cables, and loose hardware.
2. Remove, replace, and repair as necessary.
3. Visually inspect inner, outer, and shutter timing belts. Replace belts that are frayed or show signs of wear.
4. Check belt deflection (Sections 6.4.1, 6.4.2, and 6.4.3) and re-adjust if necessary.



Ultramittent should be visually checked every 30 days. If leak is detected, contact CHRISTIE to arrange for loan of substitute Ultramittent. If leak is very slow, you may continue to operate Ultramittent for 30 to 90 days.

5.3. CLEANING



Projector should be kept clean at all times.

1. Remove dust and foreign matter from projector and assemblies. Use soft, lint-free cloth, or spray with compressed air at force no greater than 20 psi.
2. Using camelhair brush or toothbrush, remove dust and foreign matter from pad rollers, sprockets, Ultramittent shoe closure, and sound idler rollers, and from pads and shoes in trap and gate assembly.
3. Using cotton-tip swabs, remove dirt and dust from sound-head optics.
4. Lightly oil lateral guide rollers and springs with very fine machine oil. Inner flange of lateral guide should move easily and should spring back to rest position without sticking.



Do not adjust lateral guides without proper alignment tool (SK1994-3).

5.4. REMOVAL OF ASSEMBLIES

The following sections contain instructions and procedures necessary to remove assemblies and components from the projector. Use only the specified tools to perform these procedures. The use of any other tools will cause damage to the assemblies and components. Appendix A contains a list of replaceable assemblies and components and their part numbers.

Removal and replacement of the assemblies discussed in Sections 5.4.1 through 5.4.13 may be performed by the customer. The customer may also repair broken leads, solder connections, and repair timing belts. All other repairs and replacements are to be performed *only* by an authorized service representative. In general, any problem that does not appear to be treatable by a minor procedure should be treated by removing the defective assembly and returning it to CHRISTIE for repair.

5.4.1. REMOVAL OF THE TRAP AND GATE ASSEMBLY

Refer to item 6 on page 2-2

1. Open trap and gate assembly by pulling catch knob (item 56 in Figure B-2).
2. Remove two socket head cap screws (item 39 in Figure B-2) securing assembly to
3. Remove assembly by gently pulling free from locating pins.
4. For projectors equipped with automatic turret, slide aperture carrier dovetail out of plunger connector.

5.4.2. OUTER TIMING BELT

Refer to Figure 5-2 below.

1. Loosen outer belt tension adjust assembly screw (item 6 in Figure 5-2) and slide idler (item 3 in Figure 5-2) up to release tension on outer timing belt (item 5 in Figure 5-2).
2. Remove outer timing belt.

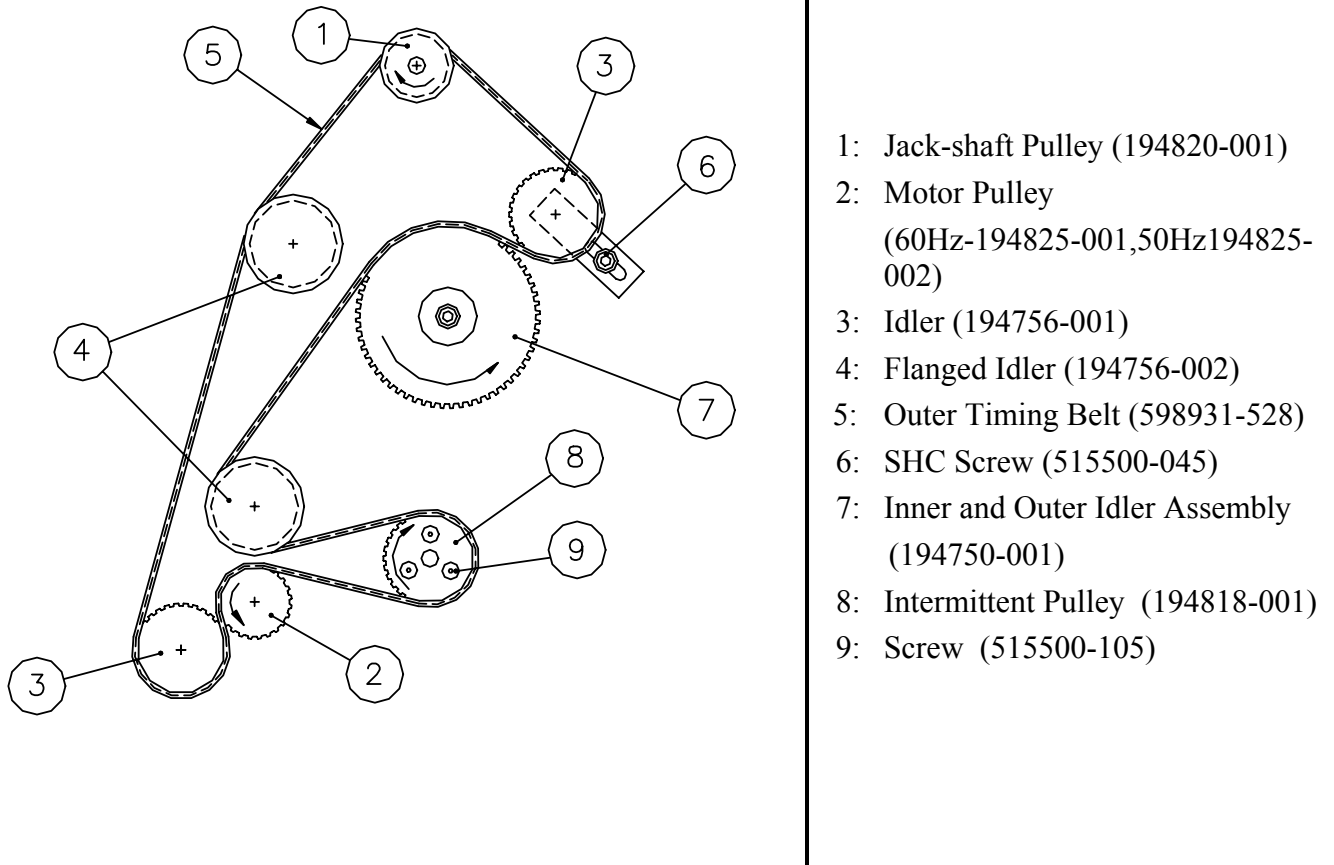

- 1: Jack-shaft Pulley (194820-001)
- 2: Motor Pulley
(60Hz-194825-001,50Hz194825-002)
- 3: Idler (194756-001)
- 4: Flanged Idler (194756-002)
- 5: Outer Timing Belt (598931-528)
- 6: SHC Screw (515500-045)
- 7: Inner and Outer Idler Assembly
(194750-001)
- 8: Intermittent Pulley (194818-001)
- 9: Screw (515500-105)

Figure 5-2: Outer Timing Belt

5.4.3. INNER TIMING BELT

Refer to Figure 5-3 below.

1. Remove outer timing belt (see Section 5.4.2).
2. Loosen adjustable inner idler pulley screw (item 1 in Figure 5-3).
3. Remove inner timing belt (item 10 in Figure 5-3).

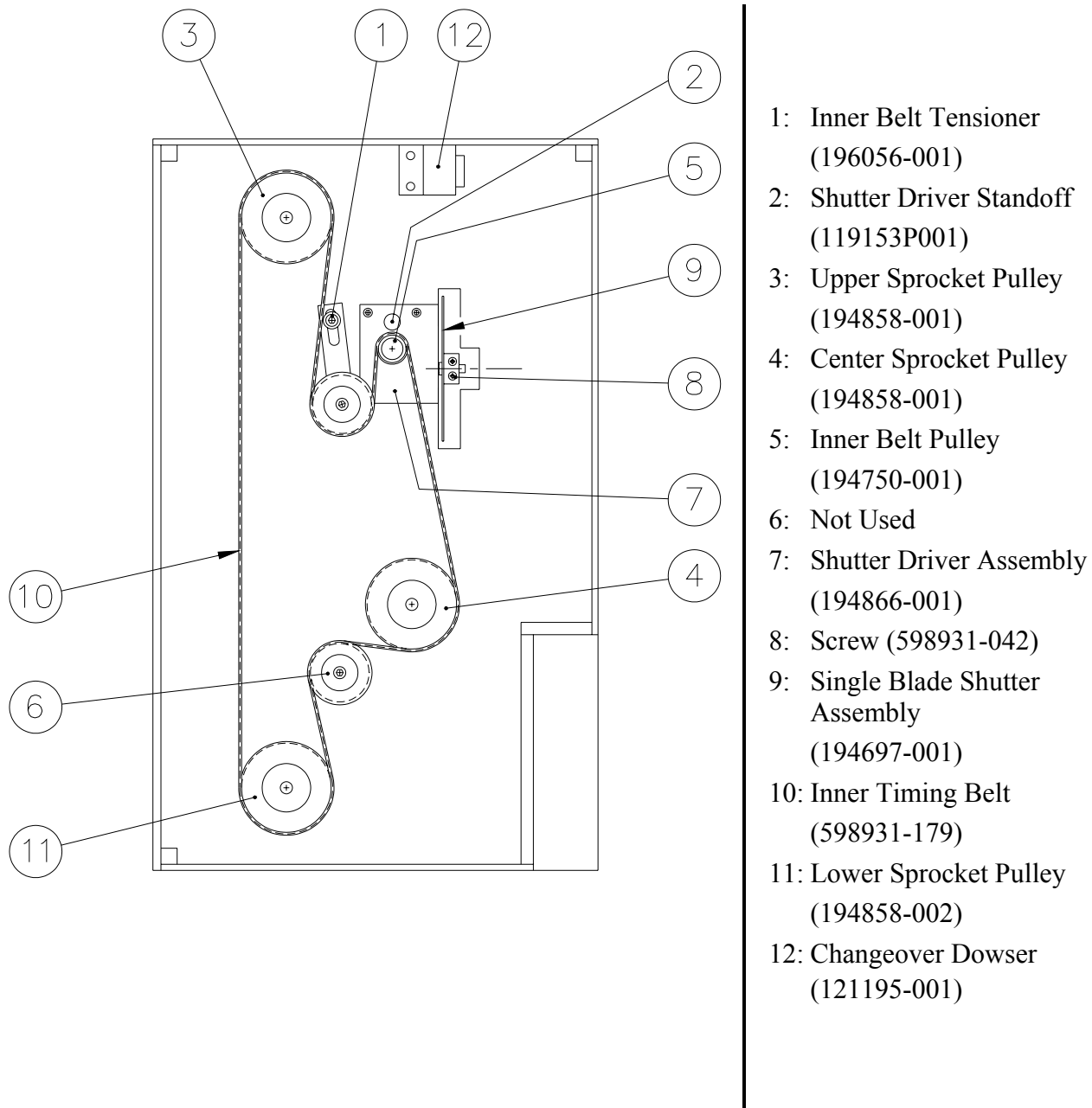
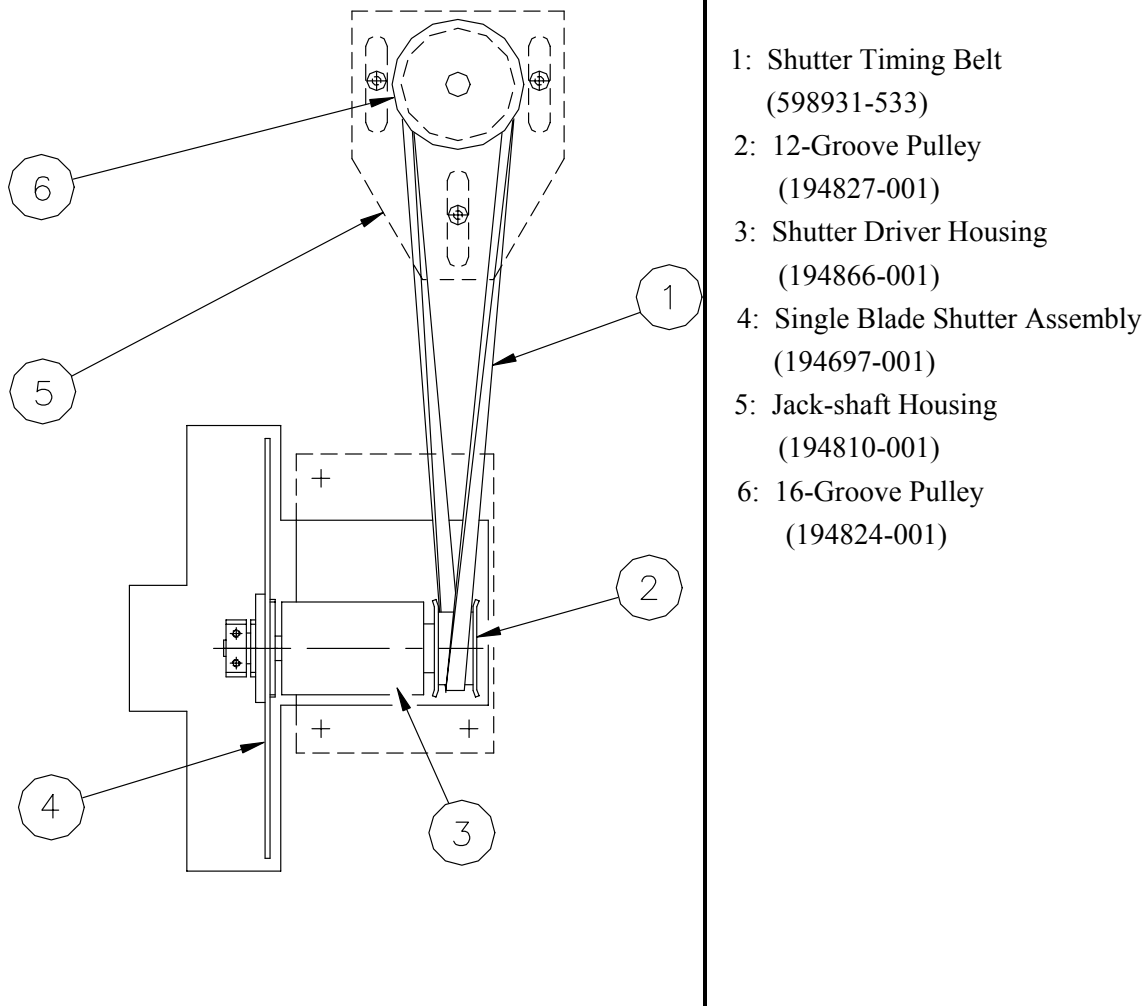

Figure 5-3: Inner Timing Belt

5.4.4. SHUTTER TIMING BELT

Refer to Figure 5-4 below.

1. Loosen three Allen head screws securing jack-shaft assembly to mainframe (item 5 in Figure 5-4).
2. Pull jack-shaft assembly down approximately 0.5 inch.
3. Remove shutter timing belt (item 1 in Figure 5-4).



- 1: Shutter Timing Belt
(598931-533)
- 2: 12-Groove Pulley
(194827-001)
- 3: Shutter Driver Housing
(194866-001)
- 4: Single Blade Shutter Assembly
(194697-001)
- 5: Jack-shaft Housing
(194810-001)
- 6: 16-Groove Pulley
(194824-001)

Figure 5-4: Shutter Timing Belt

5.4.5. UPPER, CENTER, AND LOWER CONSTANT-SPEED SPROCKET ASSEMBLIES

Refer to items 3 (center sprocket assembly) and 4 (upper sprocket assembly) on page 2-2 and item 2 (lower sprocket assembly) on page 2-3.

1. Remove inner timing belt (see Section 5.4.3).
2. Beginning with the lower sprocket assembly, remove each constant speed sprocket assembly:
 - a) Remove screw mounting turndown knob to shaft of lower constant-speed sprocket assembly (lower sprocket assembly only).
 - b) Remove turndown knob (lower sprocket assembly only).
 - c) Remove three Allen head screws from operating side of mainframe.
 - d) Carefully slide sprocket assembly out of non-operating side of mainframe.

5.4.6. ULTRAMITTENT ASSEMBLY



Disassembly of Ultramittent or attempted repair of components will void warranty.

Refer to item 5 on page 2-3.

1. Relieve tension on outer timing belt (see Section 5.4.2).
2. Remove two flat Allen head screws securing Ultramittent shoe.
3. Remove Ultramittent shoe closure assembly.
4. Remove four Allen head screws and washers securing Ultramittent assembly to mainframe.
5. *Carefully* slide Ultramittent assembly out from non-operating side of projector.

5.4.7. REMOVAL OF LED SOUND-HEAD AND SOLAR CELL ASSEMBLY

Refer to item 10 on page 2-2 and on page 2-3. See also Figure 6-1 on page 6-1.

1. Disconnect two LED leads at terminal blocks TB3-1 and TB3-2.
2. Disconnect solar cell wiring at LED pre-amp.
3. Remove four Allen head screws in corners of sound-head mounting plate.
4. Remove sound-head assembly.

5.4.8. REMOVAL OF DIGITAL SOUND-HEAD ASSEMBLY

Refer to item 10 on page 2-2 and on page 2-3. See also Figure 6-2 on page 6-4.

1. Disconnect wiring at terminal blocks TB3-1, TB3-2, TB3-4, and TB3-5.
2. Disconnect solar cell wiring at LED pre-amp.
3. Disconnect video cable for CCD assembly.
4. Remove four Allen head screws in corners of sound-head mounting plate.
5. Remove sound-head assembly.

5.4.9. REMOVAL OF ELECTRIC CHANGEOVER ASSEMBLY

Refer to item 12 in Figure 5-3 on page 5-4.

1. Carefully pull four quick connect lugs from electric changeover assembly.
2. Loosen Allen screw on dowser hub, which clamps onto flex shaft.

3. Remove flexible shaft from dowser blade.
4. Remove two Allen head screws securing electric changeover assembly to mainframe.
5. Remove changeover assembly.

5.4.10. REMOVAL OF SHUTTER DRIVER ASSEMBLY

Refer to item 7 in Figure 5-3 on page 5-4.

1. Relieve tension on outer timing belt (Section 5.4.2).
2. Relieve tension on inner timing belt (Section 5.4.3).
3. Relieve tension on shutter timing belt (Section 5.4.4).
4. Remove four Allen head screws securing shutter driver assembly.
5. Remove shutter driver assembly.

5.4.11. REMOVAL OF MOTOR ASSEMBLY

Refer to item 16 on page 2-3.

1. Disconnect motor's electrical leads at terminal block TB1-1 and TB1-2 (Figure 3-3 on page 3-4).
2. Relieve tension on outer timing belt (Section 5.4.2).
3. Remove two cable ties holding motor cable in place by removing two Allen head cap screws.
4. Remove four Allen head screws securing mounting plate with motor to motor bracket.
5. Remove motor assembly.

5.4.12. REMOVAL OF FAN

Refer to item 12 on page 2-2.

1. Remove four screws and washers securing fan to top plate of projector.
2. Pull fan up and remove A-C plug.
3. Remove fan.

5.4.13. REMOVAL OF FRAMING LAMP

1. Open framing lamp door, which is secured by two quarter-turn fasteners (item 13 on page 2-2).
2. Remove lamp as with ordinary light bulb.

6. CALIBRATION, ALIGNMENT, AND ADJUSTMENT PROCEDURES

The projector has been factory aligned, calibrated, and adjusted prior to shipment. The following paragraphs contain the necessary information to calibrate, align, and adjust the various components and assemblies. Always observe standard safety precautions and maintenance procedures when working on the projector.

6.1. ANALOG READER ALIGNMENT AND ADJUSTMENTS

Refer to Figure 6.1 for these procedures.

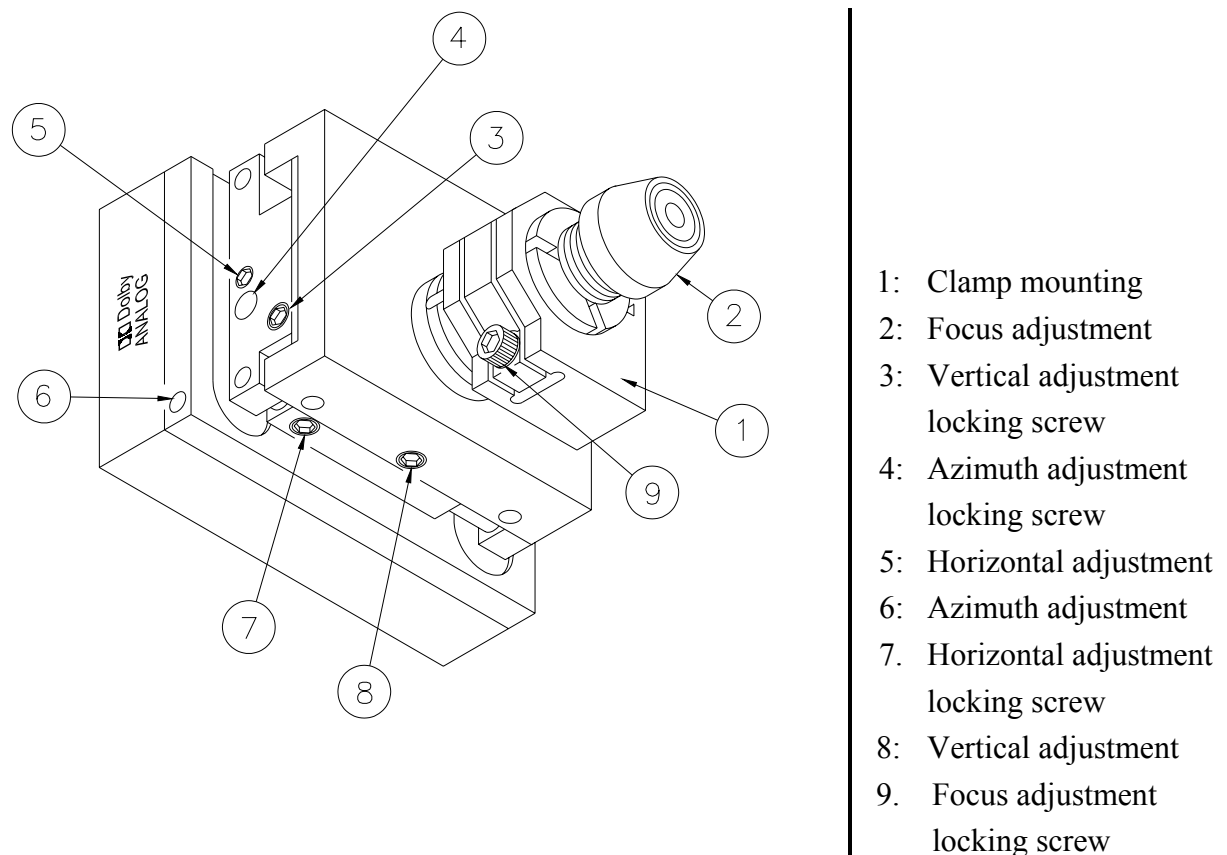

Figure 6-1: Analog Reader Assembly

6.1.1. PRELIMINARY PROCEDURES

Refer to Figure 3-2 on page 3-34 for a list of the tools, equipment, and materials required.

1. Verify that LED is operational and lens is clean.
2. Verify cell wiring for proper left/right wiring to cinema processor.

6.1.2. CELL POSITIONING: VERTICAL ALIGNMENT

1. Loosen 10-32 allen set screw on side of assembly (item 3 in Figure 6-1).
2. Run Dolby Cat. 69 tone.
3. Adjust vertical position of cell (item 8 in Figure 6-1) for maximum output level.
4. Tighten locking screw on side of cell adjustment assembly. (item 3 in figure 6-1).
5. Adjust cinema processor's pre-amplifier gains for left and right tone reference levels.

6.1.3. HORIZONTAL(LATERAL) ALIGNMENT

1. Loosen 10-32 allen set screw on bottom of cell adjustment assembly (item 7 in Figure 6-1).
2. Run Buzz Track film.
3. Adjust lateral position of cell (item 5 in Figure 6-1) until there is no output at processor's test points. If output is present on both left and right test points, increase focal distance between lens and cell.
4. Tighten locking screw on bottom of cell adjustment assembly. (item 7 in Figure 6-1).

6.1.4. FOCUS AND AZIMUTH

1. Loosen 10-32 allen set screw in hole on side of assembly (item 4 in Figure 6-1).
2. Turn cinema processor's pre-amplifier Hf adjustments counterclockwise to minimum settings.
3. Run Dolby Cat. 69 Pink Noise film (not older than 1992).
4. Adjust Focus (item 2 in Figure 6-1) and Azimuth (item 6 in Figure 6-1) for maximum high frequency response and phase coherence.
5. Carefully lock focus adjustment (9) and azimuth locking screw (4).
6. Turn cinema processor's pre-amplifier Hf adjustments clockwise until real-time analyzer shows flat frequency response to 16 kHz.
7. Verify that both channels have identical frequency response.

6.1.5. ALIGNMENT VERIFICATION

1. Repeat vertical and horizontal alignment procedures described in Sections 6.1.2 and 6.1.3.
2. Recheck to verify that optimum alignment has been achieved.

6.1.6. PERFORMANCE CHECK: CROSSTALK

1. Run Dolby Cat. 97 cell alignment film.
2. Verify that there is no crosstalk between left and right processor test points.

6.1.7. ILLUMINATION UNIFORMITY

1. Run Dolby Cat. 566 illumination uniformity film.
2. Connect left and right processor test points.
3. Verify that illumination uniformity across cell is within ± 0.5 dB.

6.1.8. FINAL CHECK

1. Verify Dolby tone reference levels.
2. Run Buzz Track film.
3. Verify frequency response and azimuth.
4. Check that all adjustment locking screws are tight.

Repeat appropriate procedures from Sections 6.1.2 through 6.1.7 if adjustments are necessary.

6.2. DIGITAL READER ALIGNMENT



The polarity of visible red LEDs may be opposite from that of infrared LEDs.

6.2.1. PRELIMINARY STEPS

1. Turn LED power supply down (CCW) to minimum.
2. Connect video cable to Digital Reader Assembly.
3. Turn on digital processor.
4. Apply AC power to projector and verify that LEDs are operational.

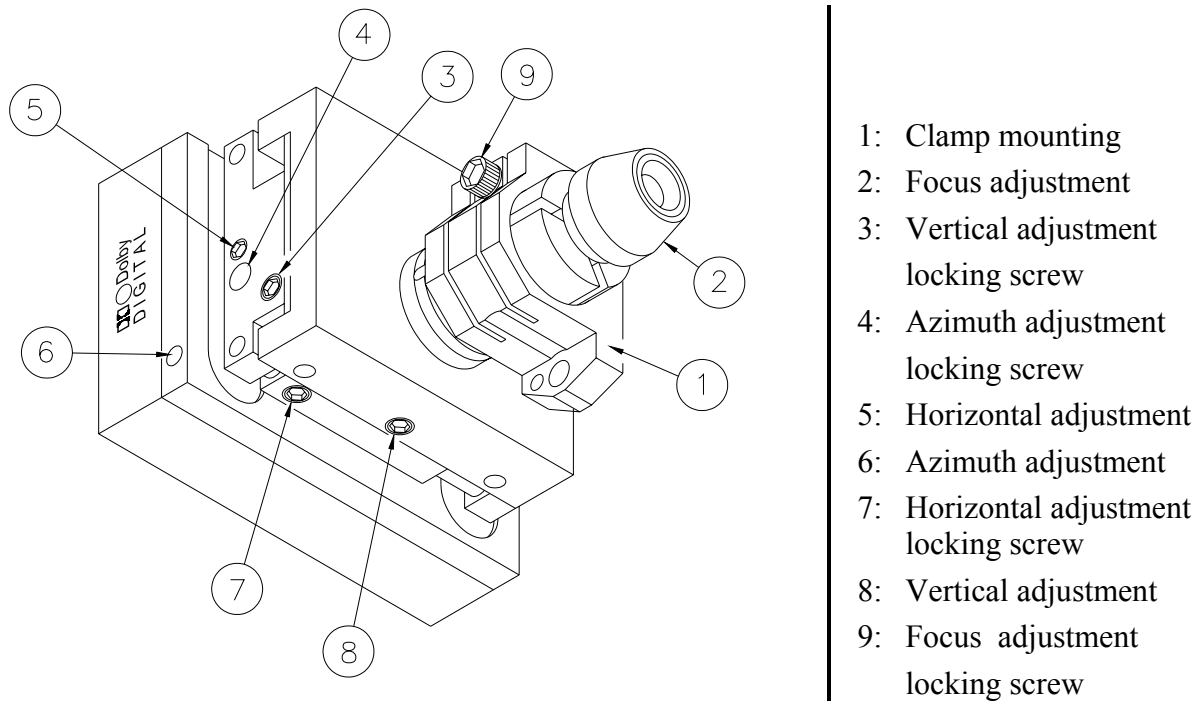

Figure 6-2: Digital Reader Assembly

6.2.2. ALIGNMENT PROCEDURE

1. Remove analog reader assembly, or rotate assembly downward, for easier access to Digital Reader Assembly.
2. Set adjustment assembly to center of travel path in both horizontal (item 5 in Figure 6-2) and vertical (item 8 in Figure 6-2) directions.
3. Run film loop with Dolby Digital track.
4. Adjust vertical positioning by pivoting entire assembly (item 1 in Figure 6-2) and fine vertical adjustments (item 8 in Figure 6-2) to achieve maximum video signal on oscilloscope.
5. Adjust with threaded lens (item 2 in Figure 6-2) at front of assembly to obtain highest possible focus reading on DRAS or QC software.



Digital reader has been factory-aligned to meet Dolby specifications. Field adjustment requires oscilloscope and either DRAS or QC software.

6. Adjust azimuth (item 6 in Figure 6-2) to read zero ± 2 mils with DRAS or QC software.
7. Adjust lateral positioning (item 5 in Figure 6-2) to center image on CCD. It should read zero ± 0.5 mils on DRAS or QC software.
8. Magnification should be 100 $\pm 2\%$; adjust focal distance if necessary.

9. Adjust LED power supply output for $4 \pm 0.5V$ of video amplitude if necessary.
10. Lock all adjustment (items 3, 4, 7, and 9 in Figure 6-2).

6.3. DASHPOT ADJUSTMENT

1. Turn hex-slotted screw counter clockwise at bottom of dashpot assembly through access hole in projector bottom plate, until friction of dashpot is at lowest point.
2. Run wow and flutter test film and increase friction by turning hex slotted screw, at bottom of dashpot assembly, clockwise until best result is obtained.

6.4. INNER, OUTER, AND SHUTTER TIMING BELT ADJUSTMENT



WARNING

NEVER adjust belts with power applied!

Belt tension should be kept as loose as possible while remaining tight enough to drive all mechanisms. To adjust belt tension, follow procedures in Sections 6.4.1 through 6.4.3.



Do not over-tighten belts. If belts are too tight, projector will not operate properly, and projector parts will wear prematurely.

6.4.1. INNER TIMING BELT

Refer to Figure 5-3 on page 5-4.

1. Loosen inner tensioner locking screw (item 1 in Figure 5-3).
2. Adjust inner timing belt pulley until belt deflection is 0.25 inch (item 10 in Figure 5-3). Belt should be just tight enough to prevent slapping.
3. Tighten locking screw (item 1 in Figure 5-3).

6.4.2. SHUTTER TIMING BELT

Refer to Figure 5-4 on page 5-5.

1. Loosen three screws securing adjust plate (item 5 in Figure 5-4).
2. Pull adjust plate (item 5 in Figure 5-4) up until belt deflection is 0.25 inch. It should be just possible to touch belt together at its midpoint.
3. Tighten screws firmly.

6.4.3. OUTER TIMING BELT

Refer to Figure 5-2 on page 5-3.

1. Loosen outer belt tension adjust assembly locking screw (item 6 in Figure 5-2).
2. Adjust outer timing belt tension assembly by turning bolt (item 8 in Figure 5-2) until belt deflection of 0.25 inch is obtained. Belt should be just tight enough to prevent slapping.
3. Tighten screw (item 6 in Figure 5-2).



Shutter timing belt must be tensioned before outer timing belt is tensioned.

6.5. SHUTTER TIMING

Refer to Figure 5-4 on page 5-5.

1. Loosen shutter clamp screws (item 8 in Figure 5-4) just enough that shutter can be rotated on its shaft.
2. Turn projector by hand with manual turndown knob until Ultramittent sprocket is in top position. Sprocket should not move while turndown knob is being turned.
3. Use sharp pencil. Carefully rest pencil point on Ultramittent casting, pointing to one sprocket tooth.
4. Without moving pencil, turn projector by hand with manual turndown knob until pencil is pointing at third tooth from starting tooth of Ultramittent sprocket.



Hold manual turndown knob to ensure that projector does not turn over while rotating shutter.

5. Rotate shutter (item 9 in Figure 5-4) by hand until crosshairs are centered in aperture. Make certain shutter is not hitting anything.
6. Tighten shutter clamp screws (item 8 in Figure 5-4). Do not allow shutter to move on its shaft after centering crosshairs.
7. Recheck shutter timing.



CHRISTIE recommends that shutter timing also be checked whenever inner, outer or shutter timing belts have been removed or replaced.

6.6. THE CHRISTIE DUAL-LENS TURRET

6.6.1. GENERAL DESCRIPTION

The CHRISTIE Turret System for the P35GPS Projector is a mechanical device holding two lenses in a rotating plate about a central axis.

6.6.2. THE MANUAL TURRET SYSTEM

The position of each lens is set manually by turning the lens holder plate in the desired FLAT or SCOPE lens position. The aperture opening matching the lens is also set manually by moving the aperture handle on the trap and gate *up* for FLAT or *down* for SCOPE.

6.6.3. THE AUTOMATIC TURRET SYSTEM

The automatic turret is electronically driven by a DC motor that controls the movements of the lens holder and the aperture. The electronics are initiated by the automation. The interfacing is done through TB4 (see schematic for P/N 503226 or 503333). The switching from SCOPE to FLAT or vice versa is done with a pulse. The common terminal of TB4-3 is briefly connected to the SCOPE terminal of TB4-4 to move the turret to the SCOPE lens position. A momentary connection between the COMMON and FLAT terminals of TB4-5 will move the turret to the FLAT lens position.

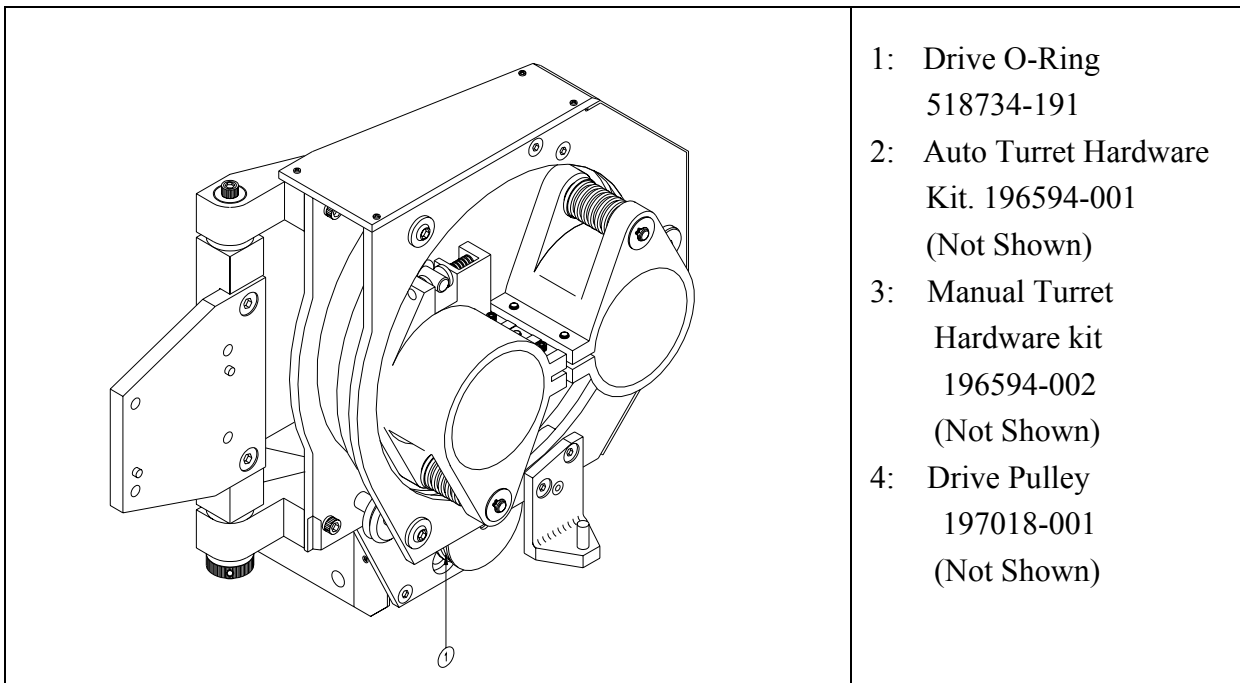

Figure 6-3: Dual Turret (Front View)

6.6.4. Timing Adjustments – Turret and Aperture Motor

The turret motor and the aperture motor are controlled from the PC board, which is mounted on the non-operator side of the projector. Both motors are timed. One timer goes to the FLAT position; another timer goes to the SCOPE position. The on-time for the FLAT position is adjusted with a trimpot located at the lower side of the PC board.



When user is facing front of projector, lensholder plate rotates clockwise to SCOPE position and counter-clockwise to FLAT position. If lensholder plate turns in opposite direction, reverse quick-connects on turret motor.

Turning the trimpot clockwise shortens the time. The timing is set approximately 0.5 seconds longer than the time needed for the turret motor to turn the lensholder plate from the FLAT position to the SCOPE position and vice versa. The drive wheel will overrun for 0.5 second. The SCOPE on-time is adjusted in the same manner, using the trimpot located on the upper side of the PC board.

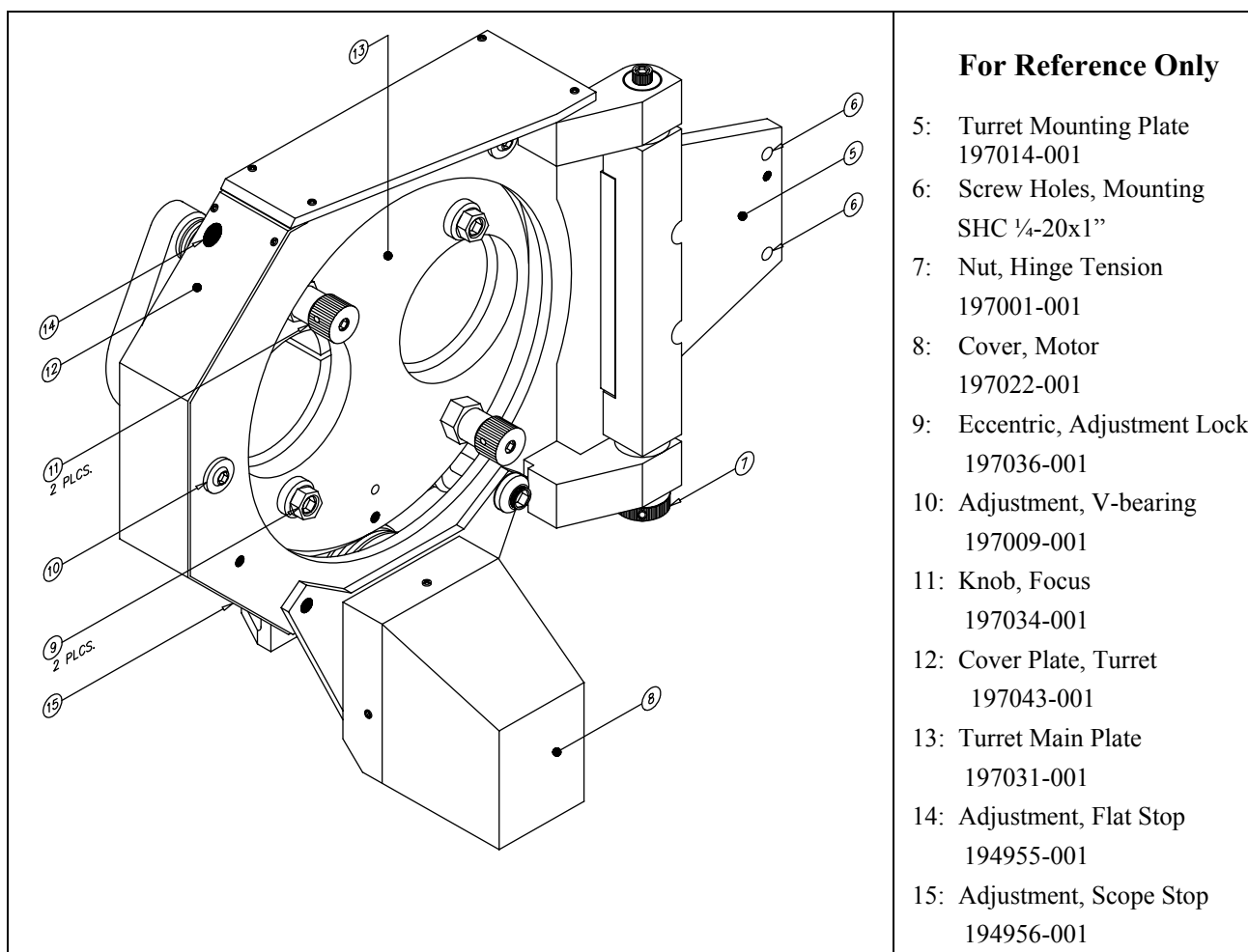

Figure 6-4: Dual Turret (Rear View)

6.7. Optical Image Alignment and Adjustment Procedures

1. With FLAT lens removed from turret, center light image on screen.
2. Level console and projector.
3. Install FLAT lens and ensure that corners of screen go dark just as bulb becomes over-focused. If necessary, move projector head using mounting plate adjustments.
4. Run RP-40 loop; adjust so that projected image is level with respect to bottom and side masking.
5. Rotate lens turret and masking to SCOPE.
6. Run RP-40 loop.
7. Center projected image vertically, using stop adjustment, and laterally, using eccentric adjustment. Adjust so that projected image is level with respect to bottom and side masking.
8. With SCOPE image vertically centered on screen, rotate lens turret and masking to FLAT.
9. Center RP-40 image vertically, using stop adjustment, and laterally, using eccentric adjustment, to match SCOPE image settings.
10. Set focus knobs to the middle of travel range.
11. File aperture plates.

7. TROUBLESHOOTING PROCEDURES



Only technicians who are familiar with the installation and adjustment procedures described in previous sections of this manual should attempt to troubleshoot or repair a problem.

This section provides information for diagnosing and troubleshooting operational problems with the P35GPS projector. While it is impossible to foresee all problems that might occur, the procedures outlined in this section should assist in identifying the problem.

Checklists and troubleshooting tables are provided for the following areas:

- Motor
- Ultramittent Assembly
- Constant Speed Sprocket Assembly
- Belts
- Changeover Assembly
- Shutter Drive (Shutter Driver and Jack-shaft Assemblies)
- Trap and Gate Assembly
- Lens Turret.

For each of these areas, one or more symptoms are described. When more than one possibility for a symptom exists, it is generally more efficient to check causes in the order in which they are listed.

Where applicable, references to the appropriate section of this manual are provided to aid in repair, replacement, and testing.

7.1. MOTOR

7.1.1. SYMPTOM: MOTOR NOT WORKING

1. Check power to motor. Verify that projector is plugged in, and that manual switch is set to ON.
2. Check start capacitor.
3. Check for motor overheating/thermal shutdown. If motor is hot, wait until it has cooled off before attempting to restart.

7.2. ULTRAMITTENT ASSEMBLY

7.2.1. SYMPTOM: EXCESSIVE TICKING

Excessive ticking is indicative of a worn star or cam. Replace Ultramittent assembly (see Section 5.4.6).

7.2.2. SYMPTOM: EXCESSIVE FILM NOISE

1. Check for improper gate tension. Use adjustment knob at top of gate assembly to correct gate tension.
2. Check for improper shoe closure or alignment.
3. If excessive film noise continues, problem may be caused by worn Ultramittent sprocket. Replace Ultramittent assembly (see Section 5.4.6).

7.2.3. SYMPTOM: FILM INSTABILITY (JUMP)

1. Verify image alignment by running RP-40 loop and making adjustments as necessary (see Section 6.7).
2. Check for worn Ultramittent sprocket. There should be no sprocket movement when manual turndown knob (item 13 in Figure 4-1 on page 4-3) is turned with Ultramittent in rest position.

7.2.4. SYMPTOM: SHUTTER STREAKING

Time shutter (see Section 6.5).

7.3. CONSTANT-SPEED SPROCKET ASSEMBLY

The following paragraphs pertain to all three (upper, center, and lower) constant-speed sprocket assemblies.

7.3.1. SYMPTOM: EXCESSIVE NOISE

1. Check for play in shaft or bearings. Adjust or replace as indicated.
2. Check for improperly aligned keeper or stripper. Realign as needed.
3. Check for loose pulley or sprocket. Tighten as needed.

7.3.2. SYMPTOM: FILM SPROCKET HOLE DAMAGE

Check for hooked or damaged sprocket. Replace as needed.

7.3.3. SYMPTOM: SPROCKET RIDING

1. Check alignment of pad roller. Adjust as needed.

2. Check pad roller arm spring mechanism. Repair or Replace as needed.

7.4. BELTS

7.4.1. SYMPTOM: EXCESSIVE NOISE

1. Check condition of all belts. Replace any belts that appear old, dry, or cracked.
2. Check tension of all belts. Adjust as needed (see Section 6.4).

7.4.2. SYMPTOM: EXCESSIVE BELT DUST

1. Check for worn or damaged pulleys. Replace as needed.
2. Check for worn or damaged idlers. Replace as needed.
3. Check condition of belts (see Section 7.4.1).

7.4.3. SYMPTOM: EXCESSIVE BELT FAILURE

1. Check condition of belts (see Section 7.4.1).
2. Check for worn or damaged pulleys. Replace as needed.
3. Check for worn or damaged idlers. Replace as needed.

7.5. CHANGEOVER ASSEMBLY

7.5.1. SYMPTOM: OPERATING INCONSISTENTLY

1. Check for faulty electrical connection. Repair as needed.
2. Check for mechanical binding or misalignment. Adjust or replace as needed.

7.5.2. SYMPTOM: NOT OPERATING

1. Check for faulty electrical connection. Repair as needed.
2. Verify power to assembly.
3. Check for open solenoid coil.
4. Check for mechanical binding.

7.6. SHUTTER DRIVE (SHUTTER DRIVER AND JACKSHAFT SYSTEM)

7.6.1. SYMPTOM: EXCESSIVE NOISE

Remove shutter belt. Localize noise to driver or jack-shaft.

1. Check rotation of bearings on shafts.
2. Replace defective component.

7.6.2. SYMPTOM: SHUTTER STREAK

1. Time shutter (see Section 6.5).
2. Check for worn pulleys. Replace as needed.
3. Check for excessively loose belts. Replace as needed.

7.7. TRAP AND GATE ASSEMBLY

7.7.1. SYMPTOM: EXCESSIVE JUMP AND WEAVE

1. Verify optical alignment with RP-40 loop (see Section 6.7).
2. Check lateral guide alignment and condition. Adjust or replace as necessary.
3. Check band tension and spring. Replace worn bands.
4. Verify that Ultramittent assembly is working properly (see Section 7.2).

7.7.2. SYMPTOM: APERTURE BINDING

1. Clean aperture carrier assembly and track.
2. Remove trap and gate assembly to check operation (see Section 5.4.1).
3. Adjust guide rails for smooth travel.
4. Check aperture drive motor with another trap and gate assembly.

7.8. LENS TURRET

7.8.1. SYMPTOM: NOT ROTATING

1. Verify module power supply reading of 24 VDC (± 2 VDC).
2. Jumper control logic at turret module, connector TB4.
3. Latch K4 to opposite position and retry.
4. Verify 24 VDC at turret motor.

7.8.2. SYMPTOM: FOCUS KNOB INOPERATIVE

1. Lens clamping screws too tight. Adjust as necessary.
2. Focus adjustment threaded out of range.
3. Bushing are binding on lens barrel shafts.

7.8.3. SYMPTOM: TURRET HINGE TOO LOOSE

Adjust bushing at base of hinge.

7.8.4. SYMPTOM: TURRET HINGE TOO TIGHT

Adjust bushing at base of hinge.

APPENDIX A: REPLACEABLE ASSEMBLIES AND COMPONENTS

Part Number	Description	Section
119263-002	Dowser Blade Assembly	5.4.6
119450-005	Ultramittent Assembly	5.4.6
120651M001	Ultramittent Shoe Closure Assembly	5.4.6
120660-001	Band for Trap and Gate	5.4.1
121117-003	Standard Aperture Plate	
121195-001	Electric Changeover Assembly	5.4.9
121205-001	Electric Changeover Coil	5.4.6
121330-001	Cooling Fan	5.4.12
196555-001	Turret Assembly (Automatic)	5.4.6
121435-001	Aperture Drive Assembly (Automatic)	5.4.6
196260-001	LED Sound-head Assembly (Central Pivot)	5.4.7
196556-001	Trap and Gate Assembly, Automatic	5.4.1
194697-001	Single Blade Shutter Assembly	5.4.10
194768-001	Motor Assembly – 60 Hz	5.4.11
194768-002	Motor Assembly – 50 Hz	5.4.11
194810-001	Jackshaft Assembly	5.4.6
194818-001	Pulley, 30-Groove (Ultramittent)	
194824-001	Jackshaft pulley, 16-Grove (Single Blade)	5.4.10
194825-001	Motor Pulley, 24-Groove (60 Hz)	5.4.11
194825-002	Motor Pulley, 29-Groove (50 Hz)	5.4.11
194827-001	Shutter Driver Pulley, 12-Groove	5.4.10
194834-001	Digital Power Supply Assembly	
194852-001	LED Sound-head Assembly	5.4.7
194856-001	Upper Constant-Speed Sprocket Assembly	5.4.5
194856-002	Center Constant-Speed Sprocket Assembly	5.4.5
194857-001	Lower Constant-Speed Sprocket Assembly	5.4.5

Table A-1: P35GPS Projector Replaceable Assemblies and Components

Part Number	Description	Section
194866-001	Shutter Driver Assembly	5.4.10
194908-001	LED/Pre-amp Power Supply Assembly	5.4.6
194909-001	Solar Cell/Pre-amp Assembly	5.4.6
196057-001	Digital Sound-head Assembly	5.4.8
196122-001	CCD Board Assembly	5.4.8
196212-002	Solar Cell/Pre-amp Assembly (Central Pivot)	5.4.7
196220-002	Digital Sound-head Assembly (Central Pivot)	5.4.8
598931-179	Inner Timing Belt	5.4.3
598931-215	Framing Lamp	5.4.13
598931-277	Rubies for Lateral Guides	
598931-528	Outer Timing Belt (two-sided)	5.4.2
598931-533	Shutter Timing Belt	5.4.4
598931-704	Visible Red LED	

Table A-1: P35GPS Projector Replaceable Assemblies and Components (Continued)

Appendix B

APPENDIX B: DIAGRAMS AND PARTS LISTS

Appendix B contains diagrams and parts lists for these major components of the P35GPS motion picture projector:

1. Changeover Dowser Assembly
2. Automatic Curved Trap and Gate Assembly
3. Fixed Idler Assembly
4. Flanged Idler Assembly
5. Jackshaft Assembly
6. Center and Upper Constant-Speed Sprocket Assembly
7. Lower Constant-Speed Sprocket Assembly
8. Shutter Driver Assembly
9. 30-Groove Flanged Idler Assembly
10. Outer Timing Belt Tensioner Assembly
11. Inner Timing Belt Tensioner Assembly
12. Central Pivot Analog Soundhead Assembly
13. Central Pivot Digital Soundhead Assembly.
14. Intermittent Shoe Closure Assembly.

B-1: CHANGEOVER DOWSER ASSEMBLY

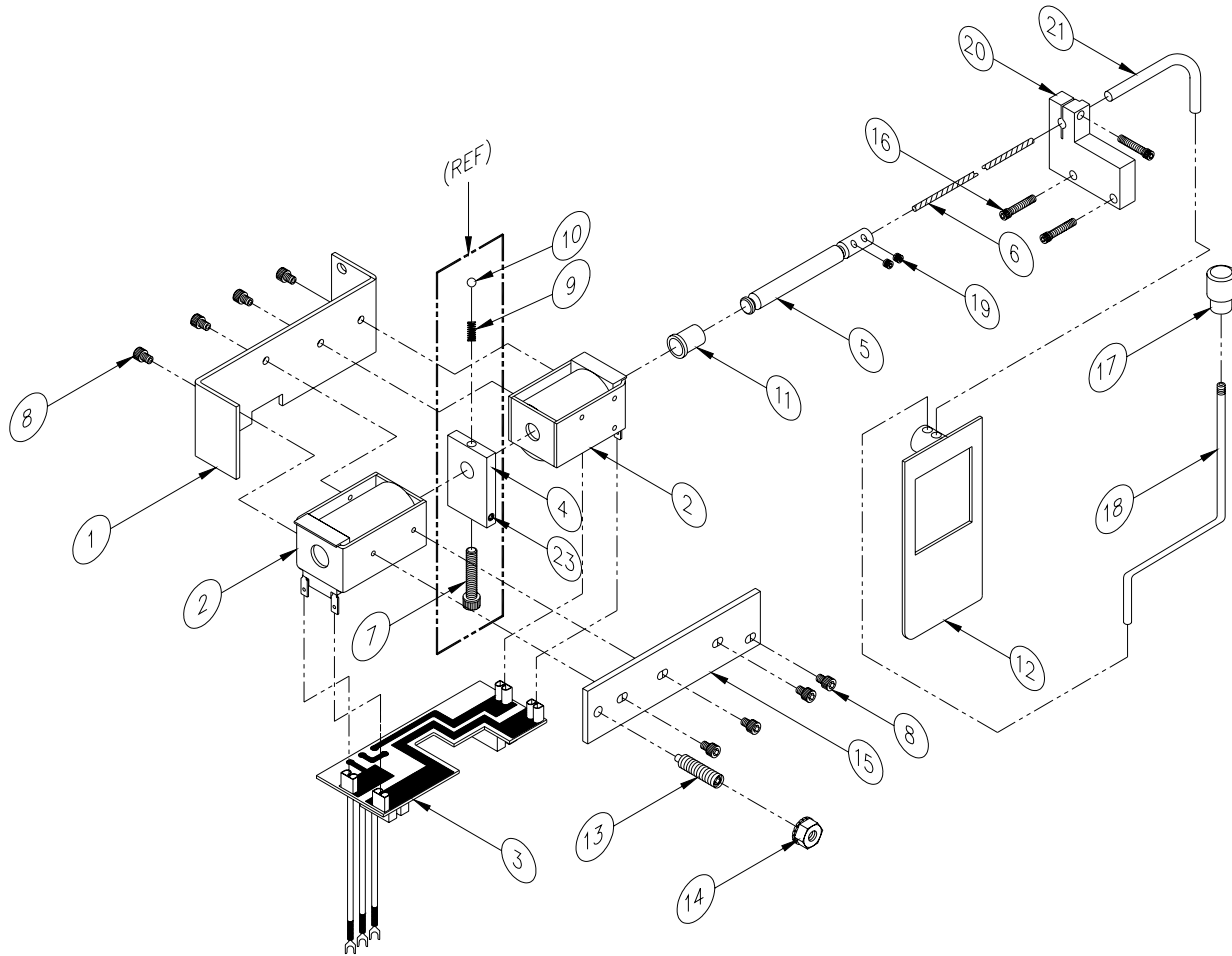

Figure B-1: Changeover Douser Assembly (P/N 196601-001)

#	Item Description	Part Number
1	Mounting Plate, Solenoid	121196P001
2	Solenoid, Modified	121205-001
3	PCB Changeover Filter Assembly	196117-002
4*	Block, Friction	121199-001
5	Plunger, Solenoid	121202-001
6	Cable, Flexible Shaft	598931-841

7*	Screw, SHC, 8-32 x 0.75 in (1.905 cm) L	598931-046
8	Screw, SHC, 6-32 x 0.1875 in (0.47625 cm) L	598931-434
9*	Spring, Compression	598931-413
10*	Ball, 0.1875 in (0.47625 cm) DIA	598931-294
11	Coupling	121650-002
12	Assembly, Dowser Blade	119263-002
13	Plunger, Spring ¼ - 20 x 0.75 in (1.905cm)	598931-372
14	Nut, Hex Jam ¼ - 20 Brass	515200-083
15	Plate, Spring Plunger	196366-001
16	Screw SHC 8-32 x 5/8 in (1.5875cm) L	598931-045
17	Knob Changeover	598931-410
18	Rod, Manual	121204-001
19	Screw, Set 6-32 X .110 In (0.2794 Cm) L	121206-001
20	Plate, Clamp	121200-001
21	Tube , Change-Over Assembly	121201-001
22	Loctite 290	598931-415
23*	Screw, Set 8-32 x 0.375 in (0.9525cm) L	598931-414
24	Changeover Upgrade Kit (NOT SHOWN)	196601-001

Dowser Blade Kit (P/N 196606-001)

#	Item Description	Part Number
12	Assembly, Dowser Blade	119263-002
17	Knob Changeover	598931-410
18	Rod, Manual	121204-001

Note: Items shown with (*) are part of the old style Changeover Douser Assembly.

Dowser Upgrade Conversion Kit (196431-001)

1	Plate Spring Plunger	196366-001
2	Plunger Solenoid	121202-001
3	Cable, Flexible Shaft	598931-841
4	Screw SHC, 6-32 x 0.1875 in (0.47625 cm) L	598931-434
5	Plunger, Spring 1/4-20x3/4	598931-372
6	Nut, Hex, Jam (THIN), 1/4-20, Brass	515200-083
7	Inst. Changeover Upgrade	TD-712

B-2: AUTOMATIC CURVED TRAP AND GATE ASSEMBLY

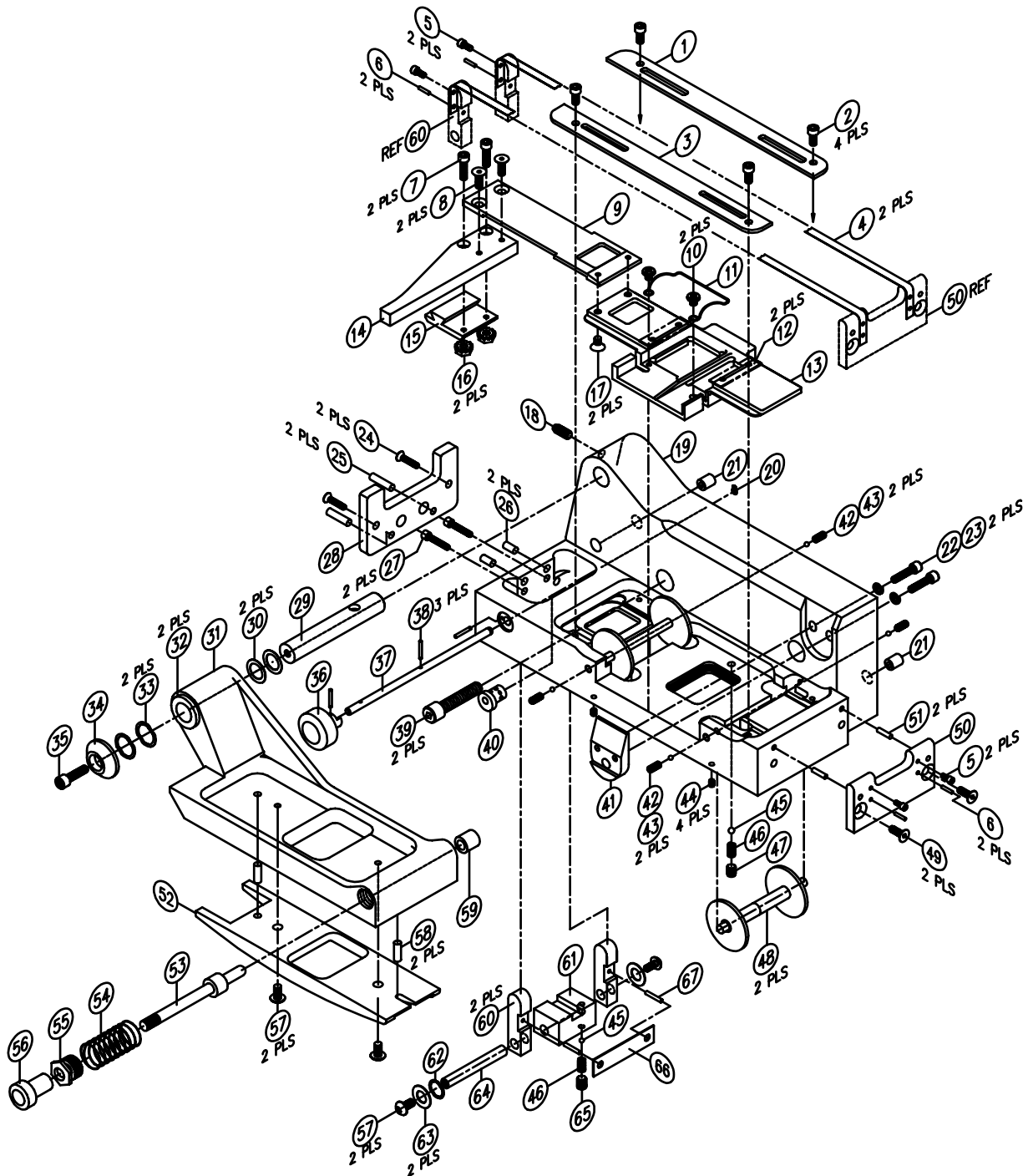

Figure B-2: Automatic Curved Trap and Gate Assembly (P/N 196556-001)

#	Item Description	Part Number
1	Rail, Inner Guide	121158-001
2	Screw, SHC, 4-40 UNC x 0.25 in (0.635 cm) L (4)	598931-038
3	Rail, Outer Guide	121159-001
4	Band, Trap and Gate (2)	120660-002
5	Screw, SHC, 2-56 UNC x 0.1875 in (0.47625 cm) L (4)	598931-403
6	Pin, Spring, 0.0625 in (0.15875 cm) DIA x 0.25 in (0.635 cm) L (4)	598931-283
7	Screw, SHC, 4-40 UNC x 0.375 in (0.9525 cm) L (2)	598931-039
8	Screw, Flat Head, 82°, 4-40 UNC x 0.25 in (0.635 cm) L (2)	598931-406
9	Connecting Link, Automatic Aperture	121154-001
10	Screw, Pan Head, Phillips, 4-40 UNC x 0.125 in (0.3175 cm) L (Modified) (2)	121277-001
11	Spring, Aperture Positioning	196058-001
12	Plate, Aperture Holder (2)	196134-001
13	Carrier, Automatic Aperture	121153-001
14	Handle	121119-001
15	Dovetail	121155-001
16	Nut, Kep, 4-40 UNC, with lock washer (2)	598931-075
17	Screw, Flat Head, 72°, 4-40 UNC x 0.20 (Modified) (2)	121279-001
18	Screw, Set, 10-32 UNC x 0.375 in (0.9525 cm) L	598931-280
19	Housing, Automatic Trap	194599-001
20	Ring, Retaining	598931-307
21	Bushing, Drill, 0.125 in (0.3175 cm) DIA (2)	598931-488
22	Washer, Split Lock, #6 (2)	598931-083
23	Screw, SHC, 6-32 UNC x 0.5 in (1.27 cm) L (2)	598931-042
24	Screw, Flat Head, 82°, 4-40 UNC x 0.375 in (0.9525 cm) L (2)	598931-407
25	Pin, Dowel, 0.125 in (0.3175 cm) DIA x 0.5 in (1.27 cm) L (2)	598931-017
26	Pin, Dowel, 0.125 in (0.3175 cm) DIA x 0.25 in (0.635 cm) L (2)	598931-404
27	Screw, SHC, 4-40 UNC x 0.5 in (1.27 cm) L (2)	598931-405
28	Guide, Film Threading	121228-001
29	Shaft, Gate	120666-001

30	Shim, Precision Shaft, 0.008 in (0.02032 cm) (2)	598931-428
31	Housing, Gate	120659-001
32	Sleeve, Bearing (2)	598931-090
33	Washer, Curved Spring (2)	598931-318
34	Cap, Gate Shaft	120670-001
35	Screw, SHC, 8-32 UNC x 0.5 in (1.27 cm) L	598931-044
36	Knob, Tensioning Band	120673-001
37	Shaft, Band Tensioning	120674-001
38	Pin, Spring, 0.0625 in (0.15875 cm) L (3)	598931-306
39	Screw, SHC, 1/4-20 UNC x 1.00 in (2.54 cm) L (2)	598931-539
40	Eccentric, Band Tensioning	120675-001
41	Plate, Catch	120663-001
42	Ball, Spherical Jewel, Ruby, 0.09375 in (0.2381 cm) DIA (4)	598931--277
43	Roller, Mount Points Lateral Guide (4)	120158-001
44	Screw, Set, Brass Tip, 4-40 UNC x 0.25 in (0.635 cm) L (4)	598931-258
45	Ball, Hardened Steel, 0.125 in (0.3175 cm) DIA (2)	598931-303
46	Spring, Compression, 0.120 OD x 0.375 L x 0.022 THK (2)	598931-304
47	Screw, Set, Slotted, 10-32 UNC x 0.160 in (0.4064 cm) L	121278-001
48	Roller, Curved Trap-and-Gate (2)	598931-257
49	Screw, Flat Head Socket, 82°, 6-32 UNC x 0.25 in (0.635 cm) L	598931-408
50	Plate, Lower End Band Connection	120661-001
51	Pin, Dowel, 0.09375 in (0.238125 cm) DIA x 0.25 in (0.635 cm) L (2)	598931-282
52	Shoe, Curved Gate	120671-001
53	Pin, Catch	120664-001
54	Spring, Compression, 0.360 in (0.9144 cm) OD x 1.0 in (2.54 cm) L x 0.043 in ((0.10922 cm) THK	598931-279
55	Bushing, Thread Catch	120665-001
56	Knob, Catch	120669-001
57	Screw, Button Head , 6-32 UNC x 0.25 in (0.635 cm) L (4)	598931-278
58	Pin, Dowel, 0.125 in (0.3175 cm) DIA x 0.375 in (0.9525 cm) L (2)	598931-016

59	Bushing, Support Pin	120672-001
60	Arm Upper End Band (2)	120677-001
61	Block, Upper End	120676-001
62	Spacer, Precision, 0.25 in (0.635 cm) OD x 0.187 in (0.475 cm) ID x 0.01 in (0.254 cm) THK	598931-338
63	Spring, Wave, 0.242 in (0.61468 cm) OD x 0.194 in (0.49022 cm) ID x 0.0057 in (0.014478 cm) THK	598931-339
64	Shaft, Upper End	120678-001
65	Screw, Set, 8-32 UNC 0.1875 in (0.47625 cm) L	598931-023
66	Spring, Band Tensioning	120679-001
67	Pin,-Spring, 0.0625 in (15875 cm) DIA x 0.375 in (0.9525 cm) L (2)	515380-041

Table B-2: Parts List for Automatic Curved Trap and Gate Assembly (Continued)

B-3: FIXED IDLER ASSEMBLY

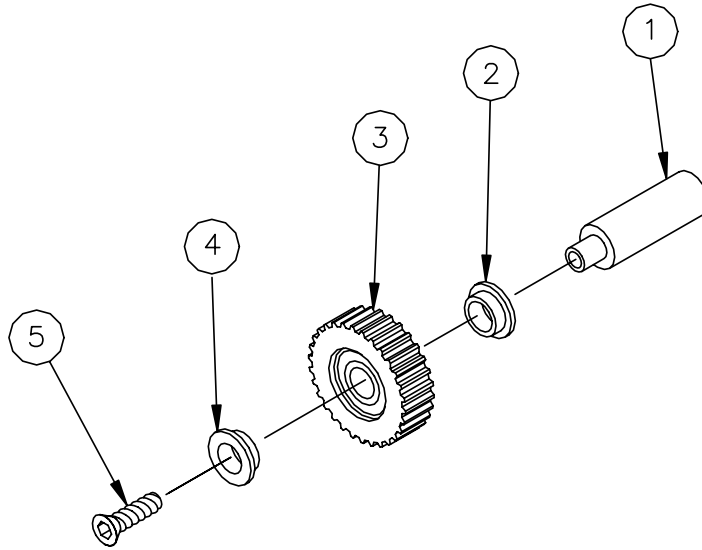

Figure B-3: Fixed Idler Assembly (P/N 194756-001)

#	Item Description	Part Number
1	Standoff	194740-001
2	Roller, Isolator	121120-001
3	Idler, 30-Groove	194895-001
4	Retainer, Bearing	119061P002
5	Screw, Flat Head Socket, 1/4-20 x 1.0 in (2.54 cm) L	598931-256

Table B-3: Fixed Idler Assembly Parts List

B-4: FIXED IDLER ASSEMBLY FLANGED

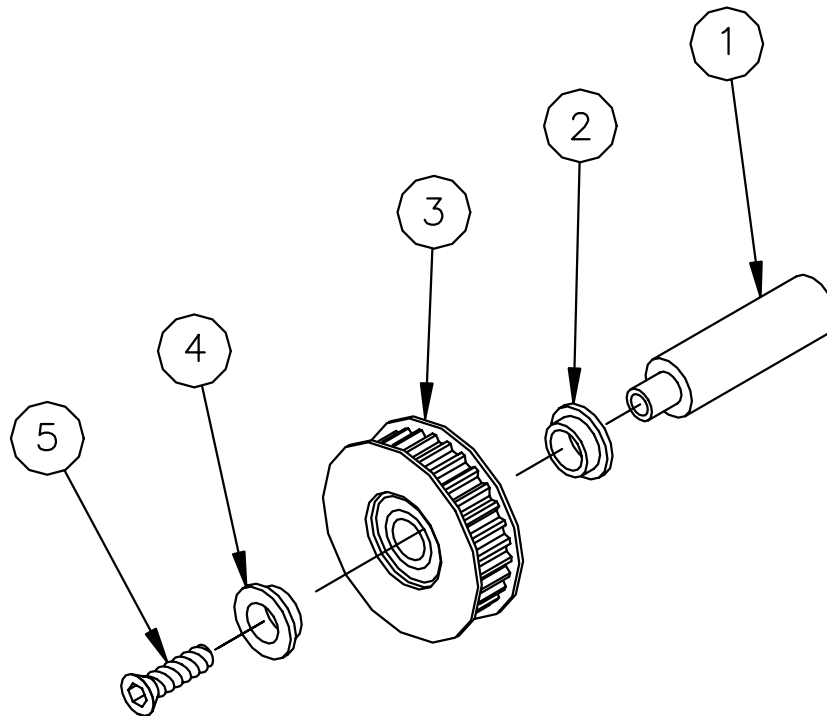
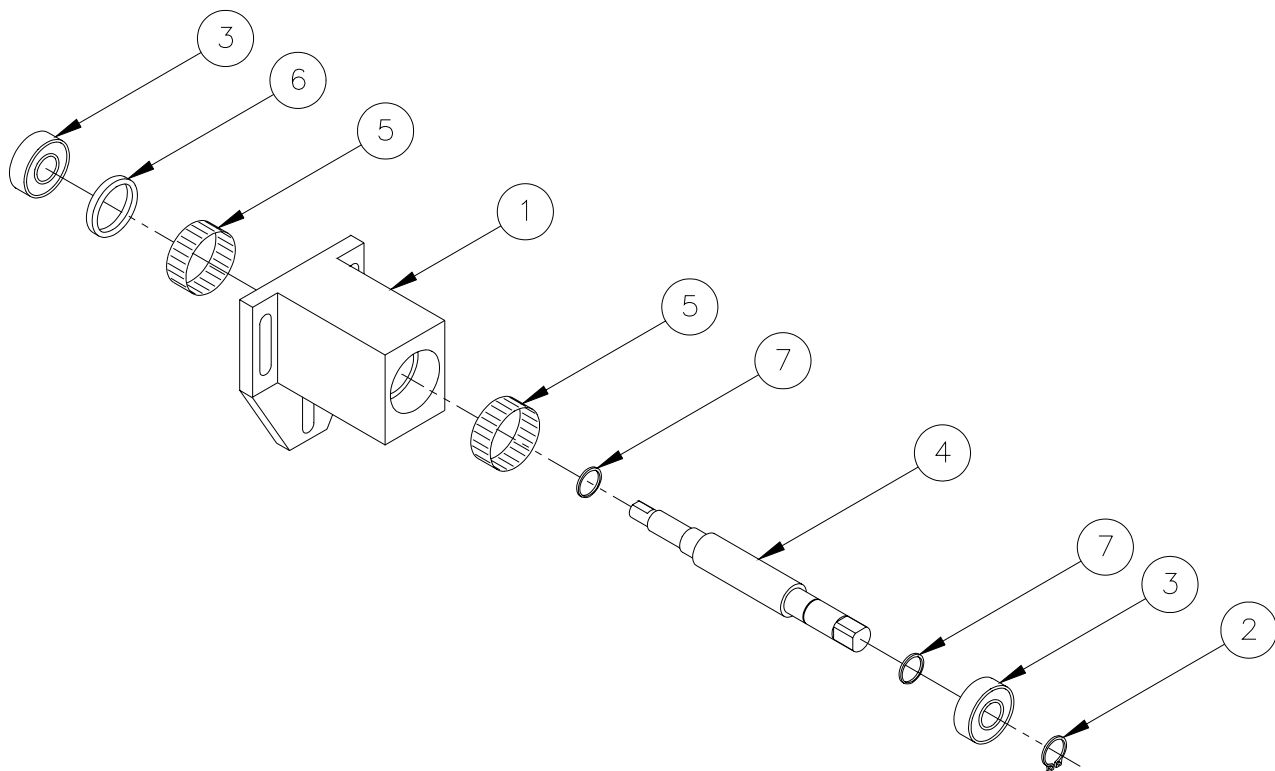

Figure B-4: Fixed Idler Assembly, Flanged (P/N 194756-002)

#	Item Description	Part Number
1	Standoff	194740-002
2	Roller, Isolator	121120-001
3	Idler, 30-Groove Flanged	194880-001
4	Retainer, Bearing	119061P002
5	Screw, Flat Head Socket, ¼-20 x 1.0 in (2.54 cm) L	598931-256

Table B-4: Fixed Idler Roller Assembly, Flanged, and Parts List

B-5: JACKSHAFT ASSEMBLY**Figure B-5: Jackshaft Assembly (P/N 194810-001)**

#	Item Description	Part Number
1	Housing, Jackshaft	194766-001
2	Ring, Retaining	598931-448
3	Ball Bearing, 0.375 in (0.9525 cm) ID x 0.875 in (2.2225 cm) OD x 0.2812 in (0.714248 cm) THK	598931-607
4	Jackshaft	194809-001
5	Tolerance Ring AN 087037-S	598931-599
6	Spacer, Jackshaft Housing	194806-002
7	Washer, Wave .397 ID x .484 OD x .009 in THK	598931-192

Table B-5: Jackshaft Assembly Parts List

B-6: CENTER AND UPPER CONSTANT-SPEED SPROCKET ASSEMBLY

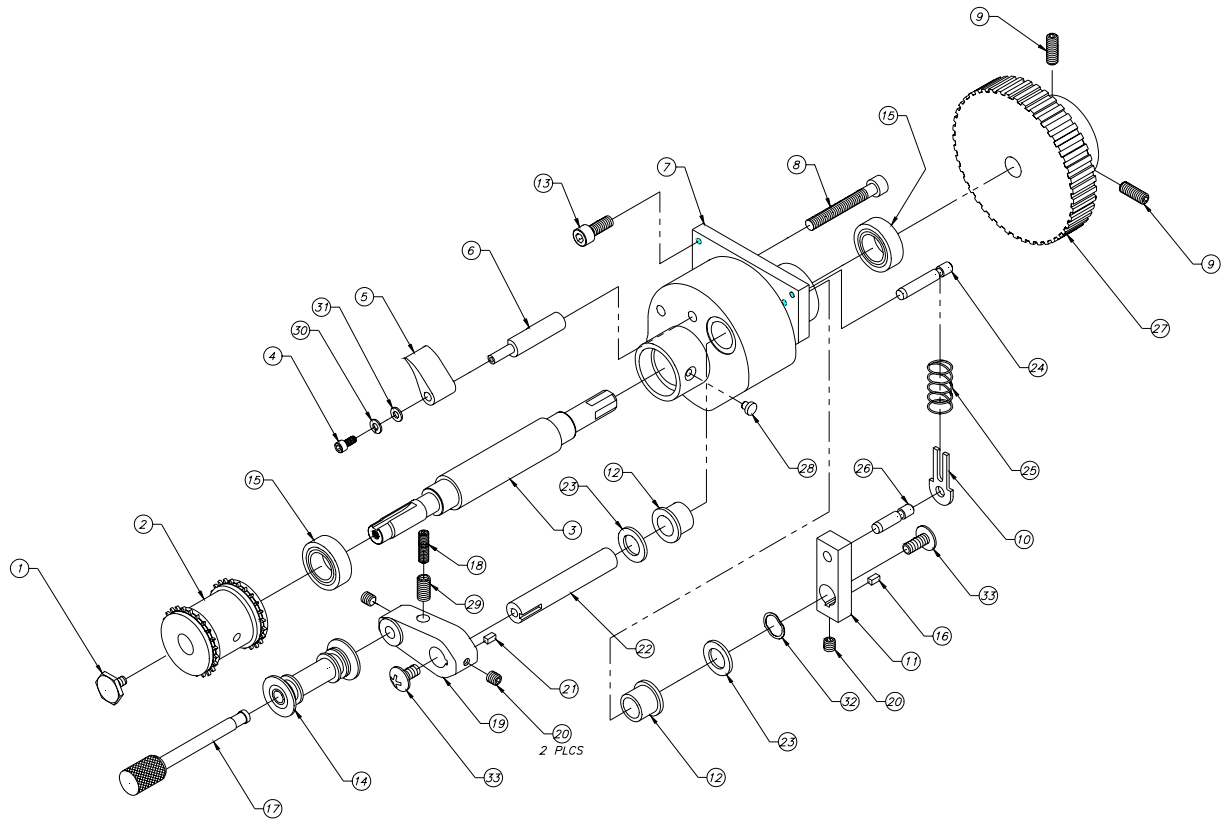

Figure B-6: Upper and Center Constant-Speed Sprocket Assembly (P/N 194856-001 -002)

#	Item Description	Part Number
1	Screw, Shaft End	119055-002
2	Sprocket, Film	598931-107
3	Shaft, Upper and Center Constant Speed Sprocket	194832-001
4	Screw, SHC, 4-40 x 0.25 in (0.635 cm) L	598931-038
5	Stripper	119107-001
6	Post, Stripper	119106-001
7	Housing, Sprocket	119103-001
8	Screw, SHC, 10-32 x 1.5 in (3.81 cm) L	598931-195
9	Screw, Socket (2)	515500-070
10	Clip, Spring Retainer	196219-001
11	Base Stud, Arm Toggle	119112-001
12	Sleeve, Bearing (2)	598931-090
13	Screw, SHC, 8-32 x 0.625 in (1.5875 cm) L (3)	598931-045
14	Pad Roller, Delrin®	598931-762
15	Bearing, 0.5 in (1.27 cm) ID x 0.8750 in (2.2225 cm) OD x 0.2812 in (0.714248 cm) THK (2)	598931-636
16	Square Key, 0.28125 in (0.714375 cm) L (2)	119073-003
17	Shaft, Pad Roller, Stud Assembly	598931-116
18	Screw, Allen, Hex Socket Set, Steel	119078-001
19	Roller Arm, Pad	119102-001
20	Screw, Set, Hex, 8-32 x 0.1875 in (0.47625 cm) L (3)	598931-023
21	Square Key	119073-003
22	Shaft, Pad Roller Arm	119109-001
23	Shaft Spacer (2)	598931-062
24	Toggle Stud, House	119112-002
25	Spring, Compression	598931-141
26	Toggle Arm	119104-001
27	Pulley, 45-Groove	194858-001
28	Stop, Pad Roller Arm	119054-001
29	Insert, Locking Screw	598931-194
30	Washer, Lock, #4	598931-209
31	Washer, Plated Flat, #4, Constant Speed	598931-427
32	Washer, Wave	598931-192
33	Screw, Truss 10-32 x 0.375 in (0.9525 cm) L (2)	598931-486

Table B-6: Center and Upper Constant-Speed Sprocket Assembly Parts List

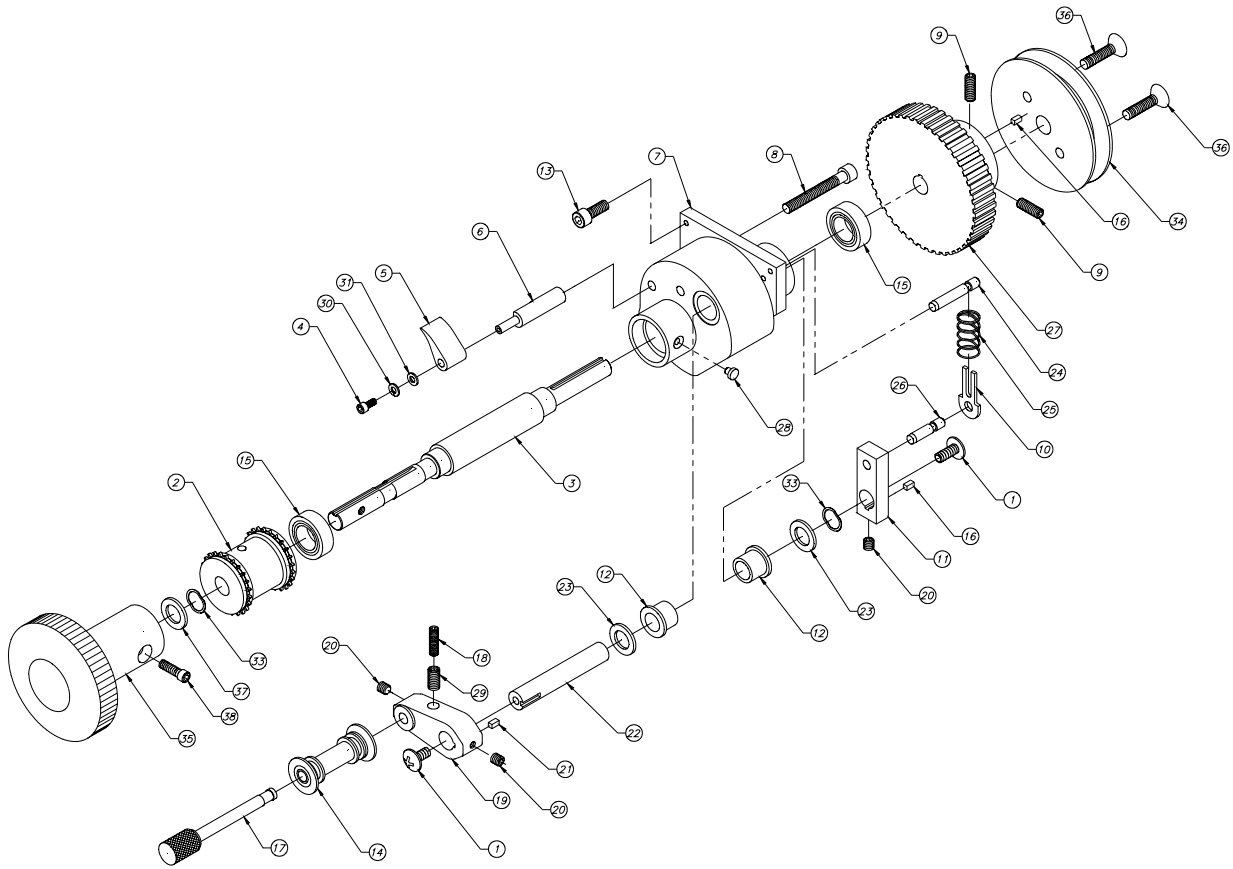

Figure B-7: Lower Constant-Speed Sprocket Assembly (P/N 194857-001)

#	Item Description	Part Number
1	Screw, Truss, 10-32 x 0.375 in (0.9525 cm) L (2)	598931-486
2	Sprocket, Film	598931-107
3	Shaft, Lower Constant Speed Sprocket	194833-001
4	Screw, SHC, 4-40 x 0.25 in (0.635 cm) L	598931-038
5	Stripper	119107-001
6	Post, Stripper	119106-001
7	Housing, Sprocket	119103-001
8	Screw, SHC, 10-32 x 1.5 in (3.81 cm) L	598931-195
9	Screw, Socket (2)	515500-070
10	Clip, Spring Retainer	196219-001
11	Base Stud, Arm Toggle	119112-001
12	Sleeve, Bearing (2)	598931-090
13	Screw, SHC, 8-32 x 0.625 in (1.5875 cm) L (3)	598931-045
14	Pad Roller, Delrin®	598931-762
15	Bearing, 0.5 in ID x 0.8750 in OD x 0.2812 in THK (2)	598931-636
16	Square Key, 0.28125 in (0.714375 cm) L (2)	119073-003
17	Shaft, Pad Roller, Stud Assembly	598931-116
18	Screw, Allen, Hex Socket Set, Steel	119078-001
19	Roller Arm, Pad	119102-001
20	Screw, Set, Hex, 8-32 x 0.1875 in (0.47625 cm) L (3)	598931-023
21	Square Key, 0.1875 in (0.47625 cm) L	119073-001
22	Shaft, Pad Roller Arm	119109-001
23	Shaft Spacer (2)	598931-062
24	Toggle Stud, House	119112-002
25	Spring, Compression	598931-141
26	Toggle Arm	119104-001
27	Pulley, 45-Groove	194858-002
28	Stop, Pad Roller Arm	119054-001
29	Insert, Locking Screw	598931-194
30	Washer, Lock, #4	598931-209
31	Washer, Plated Flat, #4, Constant Speed	598931-427
32	Screw, SHC, 10-32 x 0.625 in (1.5875 cm) L	598931-049
33	Washer, Wave (2)	598931-192
34	Pulley, Lower	119111-001
35	Knob, Turndown	194510-001
36	Screw, Head, C-Sink, 82°, 10-32 x 0.75 in (1.905 cm) L (2)	515500-429
37	Shim Spacer	598931-066

Table B-7: Lower Constant-Speed Sprocket Assembly (P/N 194857-001)

B-8: SHUTTER DRIVER ASSEMBLY

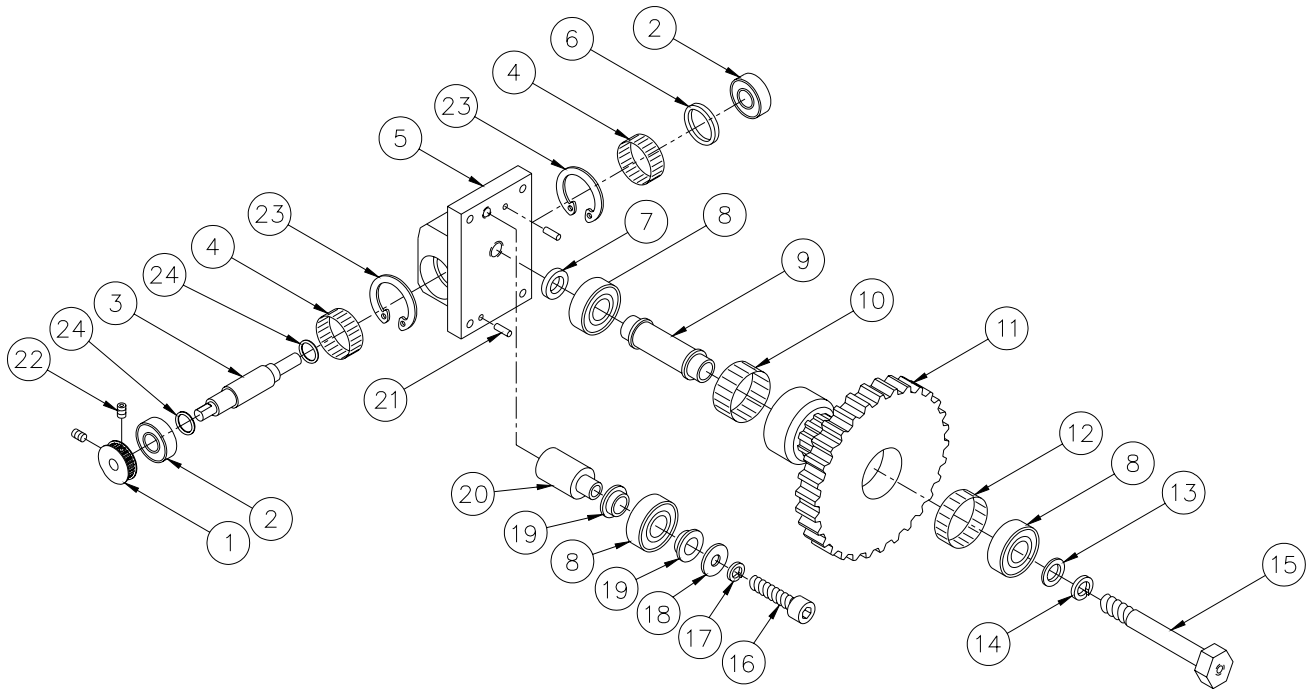

Figure B-8: Shutter Driver Assembly (P/N 194866-001)

#	Item Description	Part Number
1	Pulley, 12-Groove	194827-001
2	Ball Bearing, 0.375 in (0.9525 cm) ID x 0.875 in (2.2225 cm) OD x 0.2812 in (0.714248 cm) THK	598931-607
3	Shaft Shutter	194999-001
4	Tolerance Ring AN 087037-S	598931-599
5	Housing, Shutter Driver	194915-001
6	Spacer, Shutter Housing	194806-001
7	Standoff	194689P001
8	Ball Bearing, 0.5 in (1.27 cm) ID x 1.125 in (2.8575 cm) OD x 0.3125 in (0.79375 cm) THK	598931-608
9	Sleeve	194688-001
10	Tolerance Ring AN 112050-S	598931-592
11	Inner and Outer Idler Assembly	194750-001
12	Tolerance Ring AN 112031-S	598931-593
13	Washer, Flat 0.375 in ID x .625 O.D. x .060 THK.	515802-702
14	Washer, Split, 0.375 in (0.9525 cm.) ID SS	515819-203
15	Idler, Post	194747-001
16	Screw, Socket Cap, ¼-20 x 1.75 in (4.445 cm) L	598931-357
17	Washer, Split, 0.25 in (0.635 cm) ID	598931-086
18	Cap	119150-001
19	Roller, Isolator	121120-001
20	Standoff	119153P001
21	Pin, Dowel, 0.125 in (0.3175 cm) DIA x 0.375 in (0.9525 cm) L (2)	598931-016
22	Screw, Set, Hex Socket Cup, 6-32x 3/16	598931-022
23	Retaining Ring (Internal) Bore 15/16" Dia.	598931-159
24	Wave Washer .392 ID	598931-159

Table B-8: Shutter Driver Assembly Parts List

B-9: 30-GROOVE FLANGED IDLER ASSEMBLY

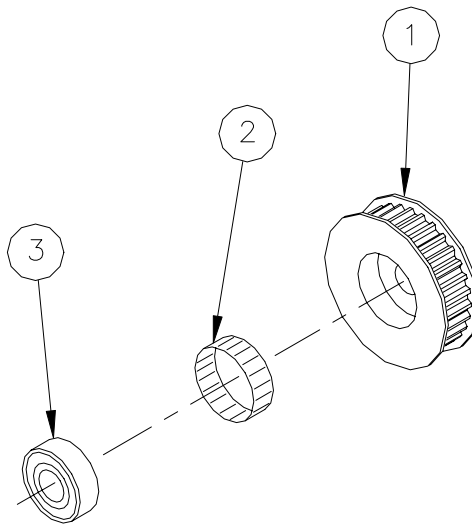

Figure B-9: 30-Groove Flanged Idler Assembly (P/N 194880-001)

#	Item Description	Part Number
1	Idler, 30-Groove Flanged	194822-001
2	Tolerance Ring, AN 112031-S	598931-593
3	Ball Bearing, 0.5 in (1.27 cm) ID x 1.125 in (2.8575 cm) OD x 0.3125 in (0.79375 cm) THK	598931-608

Table B-9: 30-Groove Flanged Idler Assembly Parts List

B-10: OUTER TIMING BELT TENSIONER ASSEMBLY

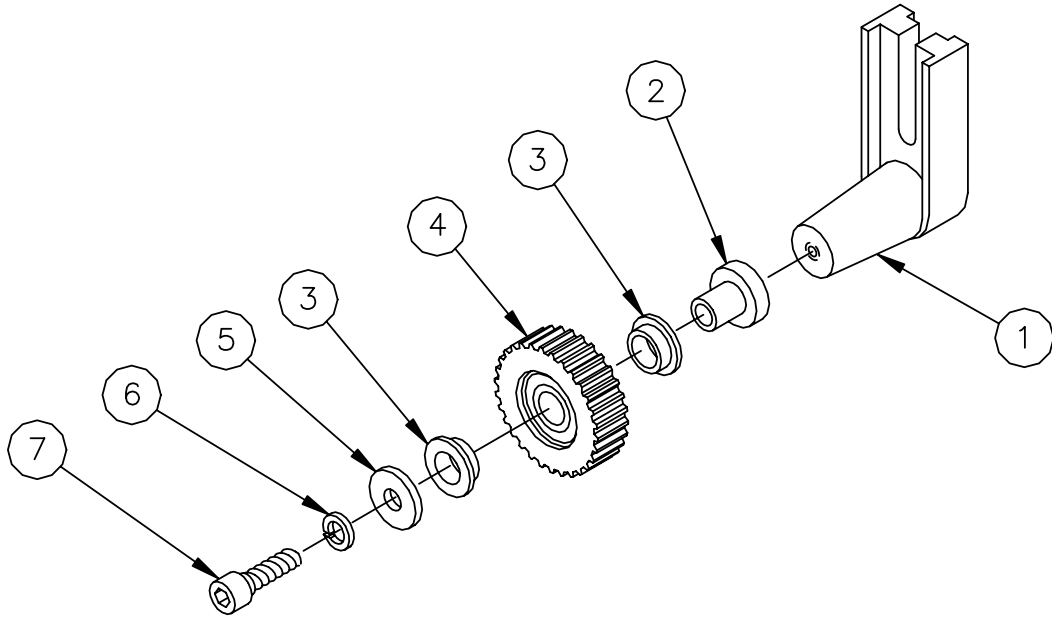

Figure B-10: Outer Timing Belt Tensioner Assembly (P/N 196055-001)

#	Item Description	Part Number
1	Base, Inner Belt Tensioner	194905-001
2	Standoff	119060P001
3	Roller, Isolator	121120-001
4	Roller, Non-Flanged Idler	194895-001
5	Cap	119150-001
6	Washer, Split, 0.25 in (0.635 cm) ID	598931-086
7	Screw, SHC, 1/4-20 x 1.0 in (2.54 cm) L	515500-105

Table B-10: Outer Timing Belt Tensioner Assembly Parts List

B-11: INNER TIMING BELT TENSIONER ASSEMBLY

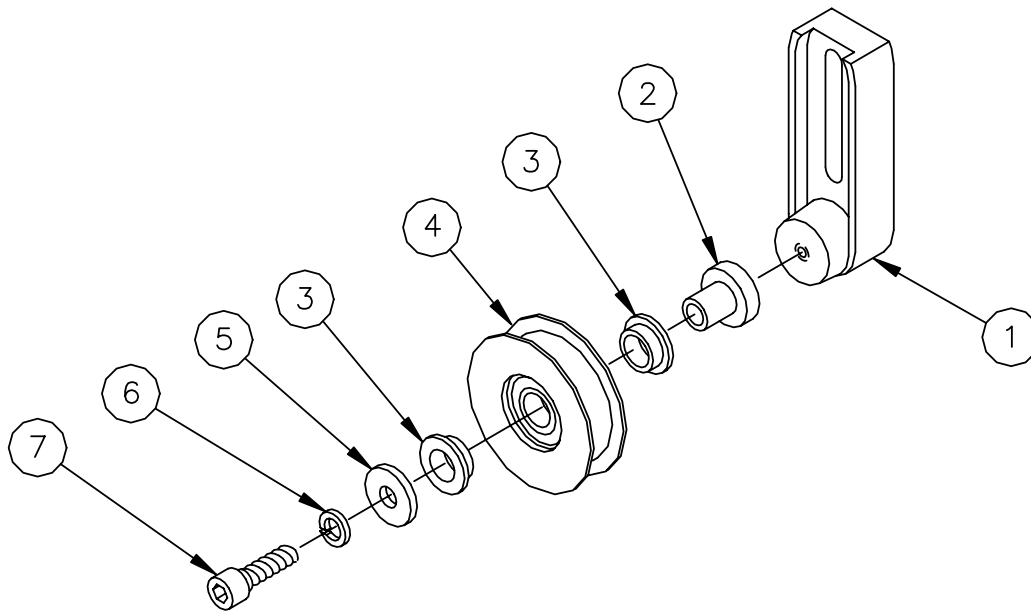

Figure B-11: Inner Timing Belt Tensioner Assembly (P/N 196056-001)

#	Item Description	Part Number
1	Base, Inner Belt Tensioner	194905-002
2	Standoff	119060P001
3	Roller, Isolator	121120-001
4	Roller, Flanged Idler (Smooth)	194782-001
5	Cap	119150-001
6	Washer, Split, 0.25 in (0.635 cm) ID	598931-086
7	Screw, SHC, 1/4-20 x 1.0 in (2.54 cm) L	515500-105

Table B-11: Inner Timing Belt Tensioner Assembly Parts List

B-12: CENTRAL PIVOT ANALOG SOUNDHEAD ASSEMBLY

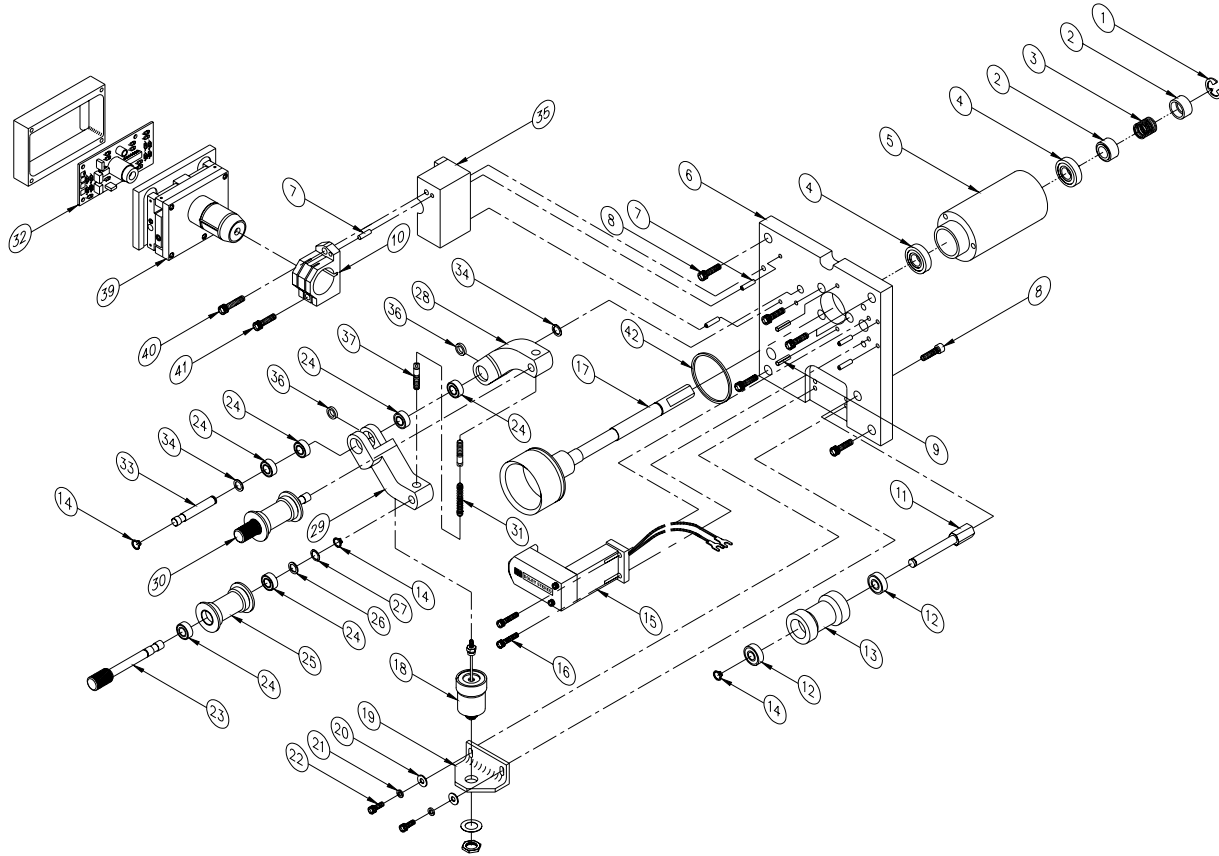

Figure B-12: Central Pivot Analog Soundhead Assembly (196260-001)

#	Item Description	Part Number
1	E Ring	598931-156
2	Spring Retainer, Sound Drum	119169-001
3	Compression Spring	598931-140
4	Ball Bearing, Flanged for Sound Head	598931-122
5	Bearing Housing	119158-001
6	Base Plate, Sound Head	196209-001
7	Dowel Pin 1/8Dia x 1/2	598931-017
8	Screw, SCH 8-32 x 5/8	598931-045
9	Spring Pin	598931-132
10	Clamp, Mount Analog Reader	196192-001
11	Shaft-35MM Film Roller	119159-001

12	Ball Bearing, by-pass Roller Assembly	598931-119
13	Roller, Film by-pass Sound Head	119168-001
14	External Retaining Ring	598931-154
15	Analog LED Assembly	196049-001
16	Screw, SHC 6-32 x 1/2	598931-042
17	Sound Drum-Shaft (DS, LED)	194798-001
18	Airpot - Snubber	598931-783
19	Dashpot Bracket, Sound Head	119160-001
20	Flat Washer #6	515819-275
21	Flat Split Lock Washer #6	515819-201
22	Screw, SHC 6-32 x 3/8	598931-041
23	Shaft, Lateral Guide Roller	119162-001
24	Bearing, Lateral Guide Roller	598931-124
25	Roller, Lateral Guide, Sound Head	119164-001
26	Shim Spacer	598931-438
27	Washer – Wave Spring	598931-439
28	Upper Arm, Block – Stabilizer	196183-001
29	Lower Arm, Block-Stabilizer	196183-002
30	Lateral Guide Roller Assembly	121312-001
31	Spring, Sound Head Sub Assembly	598931-145
32	LED Solar Cell Assy.	196212-002
33	Shaft, Arm Sound Head	196185-001
34	Shim Spacer, .020 THK.	598931-064
35	Mount, Bracket LED Reader	196224-001
36	Spacer, Bearing, Analog / Digital	196210-001
37	Spring Anchor	196205-001
38	Shim Spacer, .010 THK. (Optional)	598931-063
39	Analog Reader Assy.	196179-002
40	Screw, Socket Head Cap 8-32 x 5/8"	515500-100
41	Screw, 8-32 x 1/2"	598931-044
42	O-ring, 1 1/2" ID x 1-5/8" OD x 1/16	598931-097

Table B-12: Central Pivot Analog Soundhead Assembly Parts List

B-13: CENTRAL PIVOT DIGITAL SOUNDHEAD ASSEMBLY

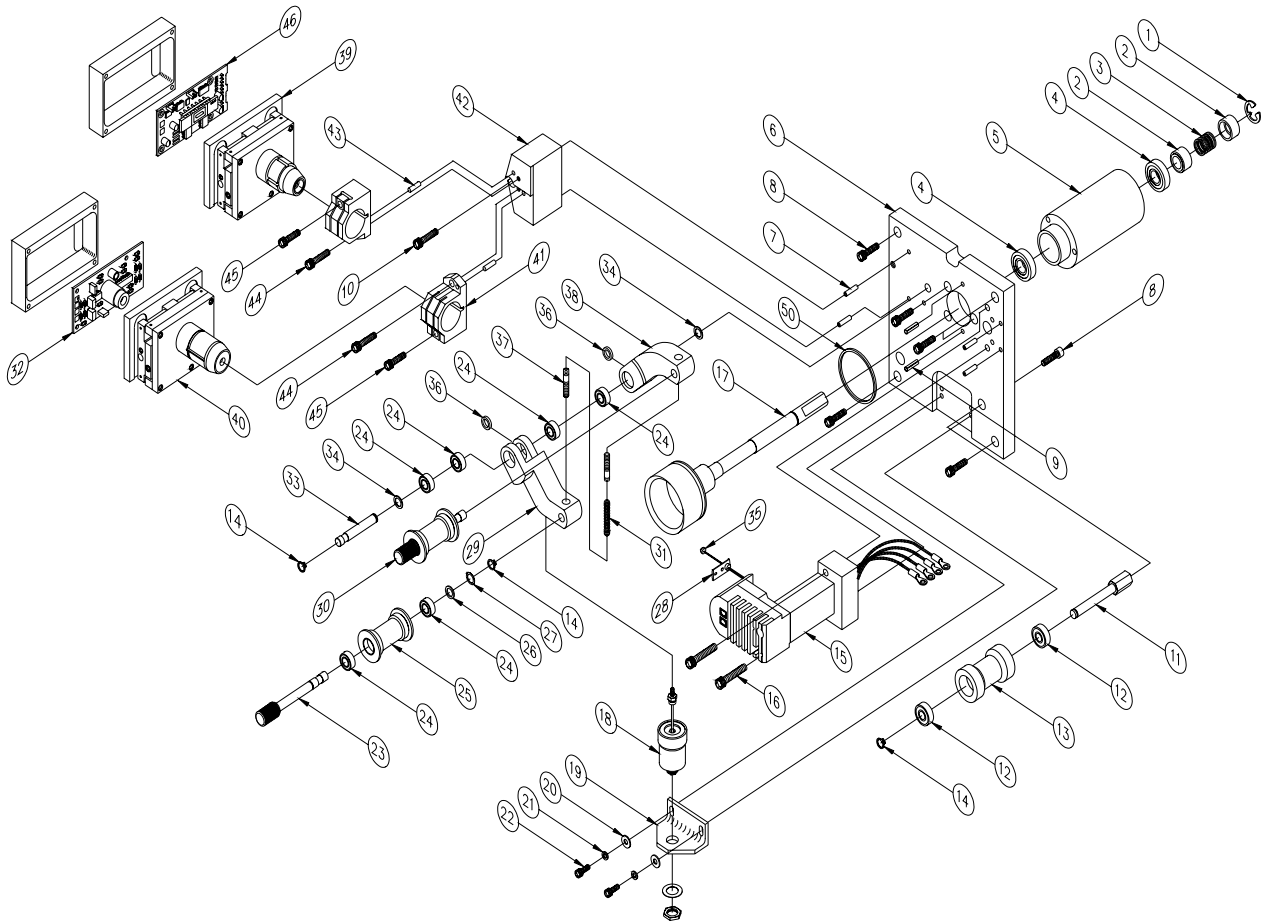

Figure B-13: Central Pivot Digital Soundhead Assembly (196220-002)

#	Item Description	Part Number
1	E Ring	598931-156
2	Spring Retainer, Sound Drum	119169-001
3	Compression Spring	598931-140
4	Ball Bearing, Flanged for Sound Head	598931-122
5	Bearing Housing	119158-001
6	Base Plate, Sound Head	196209-001
7	Dowel Pin 1/8Dia x 1/2	598931-017
8	Screw, SCH 8-32 x 5/8	598931-045
9	Spring Pin	598931-132

10	Screw, Socket Head Cap 10-32 x 3/4	515500-016
11	Shaft-35MM Film Roller	119159-001
12	Ball Bearing, by-pass Roller Assembly	598931-119
13	Roller, Film by-pass Sound Head	119168-001
14	External Retaining Ring, by-pass Roller Assembly	598931-154
15	Dual LED Mount Assembly	196184-001
16	Screw, SHC 10-32 x 1	598931-197
17	Sound Drum-Shaft (DS, LED)	196315-001
18	Airpot - Snubber	598931-783
19	Dashpot Bracket, Sound Head	119160-001
20	Flat Washer #6	515819-275
21	Flat Split Lock Washer #6	515819-201
22	Screw, SHC 6-32 x 3/8	598931-041
23	Shaft, Lateral Guide Roller	119162-001
24	Bearing, P35 Lateral Guide Roller Assembly	598931-124
25	Roller, Lateral Guide, Sound Head	119164-001
26	Shim Spacer	598931-438
27	Washer – Wave Spring	598931-439
28	LED Retainer Analog/Digital	196156-001
29	Lower Arm, Block-Stabilizer	196183-002
30	Lateral Guide Roller Assembly	121312-001
31	Spring, Sound Head Sub Assembly	598931-145
32	LED Solar Cell Assembly	196212-002
33	Shaft, Arm Sound Head	196185-001
34	Shim Spacer, .020 THK.	598931-064
35	LED, Visible Red	598931-704
36	Spacer, Bearing, Analog / Digital	196210-001
37	Spring Anchor	196205-001
38	Upper Arm, Block – Stabilizer	196183-001
39	Digital Reader Assembly	196182-001
40	Analog Reader Assembly	196179-002
41	Clamp Mount Analog / Digital Sound Head	196192-001
42	Mount Bracket Analog / Digital	196191-001
43	Dowel Pin 1/8Dia x 1/2	598931-017
44	Screw Socket Head Cap 8-32 x 5/8	515500-100

45	Screw Socket Head Cap 8-32 x 1/2	598931-044
46	CCD Assembly	196122-001
47	Digital Power Supply Assembly (Not Shown)	194834-001
48	LED Power Supply Assembly (Not Shown)	194908-001
49	Shim Spacer .010 THK. (Optional) (Not Shown)	598931-063
50	O-ring, 1 1/2" ID x 1/16"	598931-097

Table B-13: Central Pivot Digital Soundhead Assembly Parts List

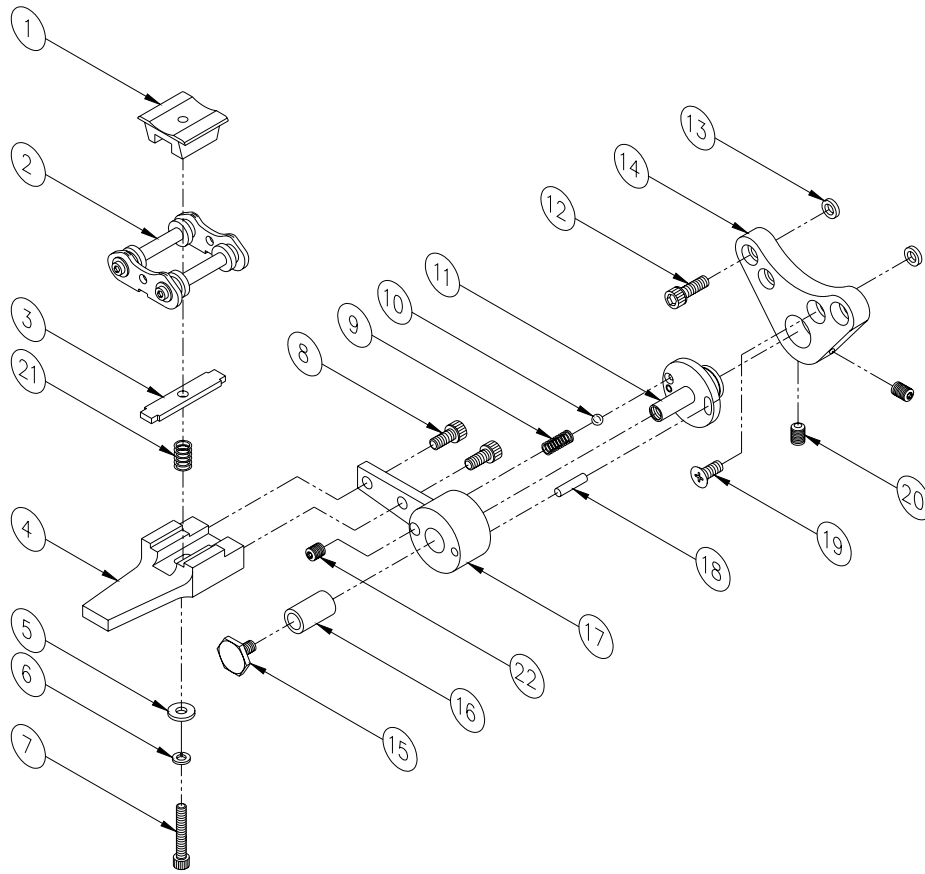

Figure B-14: Intermittent Shoe Closure Assembly (120651M001)

#	Item Description	Part Number
1	Block, Aligning Pressure Pad	119075-001
2	Film Guide Ultramittent Shoe Assembly, Delrin	196610-001
3	Balance – Bar	194840-001
4	Extension Arm, Film Guide Shoe Closure	120557-001
5	Flat Washer #6	598931-068
6	Washer, Split #6	598931-083
7	Screw, SHC, 6-32 UNC x 0.875 in (2.2225 cm) L	598931-043
8	Screw, SHC, 8-32 UNC x 0.375 in (0.9525 cm) L (2)	598931-409

9	Spring Compression .180 in (.04572 cm) OD	598931-832
10	Ball .1875 in (0.4763 cm) DIA	598931-294
11	Shaft, Ultramittent Shoe Closer	120653-001
12	Screw, SHC 8-32 UNC x 0.5 in (1.27 cm) L	598931-044
13	Shim .057 in (0.1448 cm) THK. (2)	598931-416
14	Base, Ultramittent Pressure Pad	120654-001
14	Base, Ultramittent Pressure Pad	120654-002
15	Screw, Hex Flat Head	598931-893
16	Sleeve Bearing	598931-289
17	Arm, Ultramittent Film Guide Shoe	120652-001
18	Pin, Dowel, 0.125 in(0.3175 cm) DIA x .05 in(1.27cm)L	598931-017
19	Screw, Flat Head Phillips 8-32 UNC x 0.5 in (1.27cm) L	598931-213
20	Screw, Set, Hex, 10-32 UNC x 0.25 in (.635 cm) L (2)	598931-025
21	Spring Compression, Extension Arm	598931-621
22	Screw, Set, Hex 10-32 UNC x 0.1875 in (0.4763 cm) L	598931-299
	Loctite 271	598931-412

Table B-14: Intermittent Shoe Closure Assembly Parts List

Appendix C

APPENDIX C: SCHEMATIC DIAGRAMS

Table C- 1 lists the schematics for the P35GPS projector that are included with this manual.

Diagram	Part Number
Analog wiring diagram	194908
Digital wiring diagram	194834
Projector wiring 60Hz	503226

Table C- 1: Schematic Diagrams for P35GPS Projector

The schematics are oversize, and are found at the back of the manual.

P35 GPS Dual Lens Turret Projector

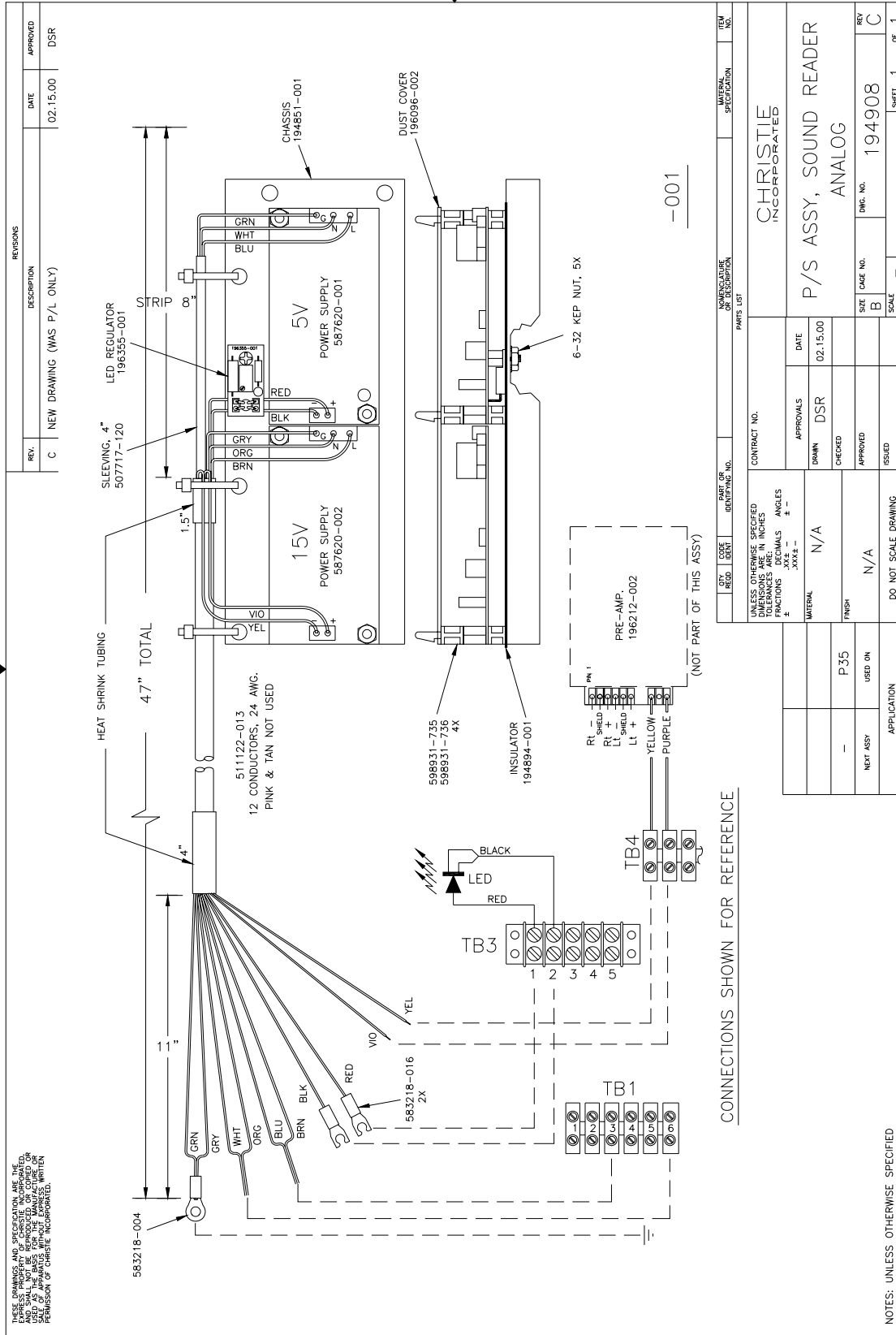

INDEX

A	Electrical Connections	3-3
Airpot	4-3	
Alignment, Azimuth		
Adjustment	6-1	
Set Screw	6-1	
Alignment, Horizontal		
Adjustment	6-1	
Set Screw	6-1	
Alignment, Vertical		
Adjustment	6-1	
Alignment, Vertical		
Set Screw	6-1	
B		
Belts	5-1	
C		
Cat 566 Loop	3-3	
Cat 69 Loop	3-3	
Cat 97 Loop	3-3	
Changeover Douser	5-4	
Constant-Speed Sprocket Assemblies		
Removal	5-5	
Constant-Speed Sprocket Assembly, Center		
	4-2, 4-3	
Pulley	5-4	
Constant-Speed Sprocket Assembly, Lower		
	4-2, 4-3	
Pulley	5-4	
Constant-Speed Sprocket Assembly, Upper		
	4-2, 4-3	
Pulley	5-4	
D		
Digital Soundhead Assembly		
Removal	5-6	
Dual Lens Turret		
Installation	4-1	
Dual-Lens Turret	3-1	
E		
Electric Changeover Assembly		
Removal	5-6	

F

Fan	
Removal	5-7
Film	
Threading	4-2
Flywheel	3-1
Installation	4-1
Focus	
Adjustment	6-1
Framing Knob	4-2, 4-3
Framing Lamp	
Removal	5-7

I

Inner Belt Tensioner	5-4
Inner Timing Belt	5-3, 5-4, 5-7
Pulley	5-4
Installation	3-1
Intermittent	
Pulley	5-3

J

Jackshaft Assembly	5-4
Jackshaft Pulley	5-3

L

Lateral Guide Roller	4-3
Lateral Guide Rollers	5-2
LED Soundhead Assembly	
Alignment	6-1
Removal	5-6
Lens	
Installation	4-2

M

Maintenance	
Cleaning	5-2
Frequency	5-1
Visual Inspection	5-1
Manual Turn-Down Knob	4-3, 5-5
Motor Assembly	
Removal	5-7
Motor Pulley	5-3

O

Outer Timing Belt	5-3, 5-6, 5-7
Removal	5-3

P

P35-BT	3-3
P35-FL	3-3
P35GPS Projector	
Optional Features	2-1
Standard Specifications	2-1
P35GPS Projector	
Shipping Configuration	3-1
Projector Wiring	3-5

R

RP-40 Loop	3-3
------------	-----

S

Shutter Driver Assembly	5-4
Removal	5-7
Shutter Driver Housing	5-5
Shutter Driver Standoff	5-4
Shutter Timing Belt	5-5, 5-7
Signal-to-Noise Ratio	3-3
Single Blade Shutter Assembly	5-4, 5-5
Solar Cell Assembly	
Removal	5-6
Solar Cell Wiring	3-3
Soundhead Assembly	3-1, 4-2, 4-3. <i>See</i>
Soundhead Flywheel	3-1

T		Removal	5-6
<hr/>			
Trap and Gate Assembly	4-3, 4-4		
Removal	5-2		
U		V	
<hr/>			
Ultramittent	2-1, 4-2, 4-3, 4-4	Visual Inspection	5-1
Ultramittent Assembly			

WARRANTY
COVERING
M / P35GPS PROJECTOR

Manufactured by: CHRISTIE DIGITAL SYSTEMS
(Herein referred to as "**Christie**")

Christie warrants the apparatus sold to the extent of the parts necessary to correct any defect in workmanship or materials which may develop under proper and normal use for a period of one (1) full year (90 days on electric motors) from the date of installation (except as noted below) but not to exceed eighteen (18) months from the date of shipment from CHRISTIE DIGITAL SYSTEMS.

Christie reserves the right to have the apparatus returned, freight prepaid, to Christie factory to effect the warranty repairs.

Replacement parts for warranty repairs will be shipped promptly by Christie f.o.b. factory, and invoiced to the customer. Credit will be issued upon return of the defective part(s), prepaid, to the Christie factory.

The above shall constitute a fulfillment of all Christie liabilities in respect to said apparatus.

This warranty does not cover:

Special customer specified purchased parts, materials, or components modified to customer specifications.

This warranty does not apply to parts of any Christie product, which have been opened, disassembled, repaired, or altered by anyone other than Christie, or subjected to misuse or abuse.

Christie shall not be liable for any consequential damages.